



Instructions and Maintenance Manual

Dual-Rod Cylinder
Series 55-CXSW

CE II 2GD c 65°C (T6) Ta -10°C to 40°C
85°C (T5) Ta 40°C to 60°C

Read this manual before using this product.

For future reference, please keep this manual in a safe place.

The information within this document is to be used by pneumatically trained personnel only.

This manual should be read in conjunction with the current catalogue.

Marking description		
II 2GD c	65°C (T6)	Ta -10°C to 40°C
	85°C (T5)	Ta 40°C to 60°C
Group II		
Category 2		
Suitable for Dust and Gas environment		
Type of protection "constructional safety"		
Max surface temperature 65°C and temperature class T6 when ambient temperature is from -10°C to 40°C		
Max surface temperature 85°C and temperature class T5 when ambient temperature is from 40°C to 60°C		

1 SAFETY RECOMMENDATION

1.1 General recommendation

These safety instructions are intended to prevent a hazardous situation and/or equipment damage. These instructions indicate the level of potential hazard by label of "Caution", "Warning" or "Danger". To ensure safety, be sure to observe ISO4414 (Note1), JIS B 8370 (Note2) and other safety practices.

Note1: ISO 4414: Pneumatic fluid power - General rules relating to systems. Note 2: JIS B 8370: Pneumatic system axiom.

CAUTION: Operator error could result in injury or equipment damage.

WARNING: Operator error could result in injury or loss of life.

DANGER: In extreme conditions, there is possible result of serious injury or loss of life.

WARNING

- The compatibility of pneumatic equipment is the responsibility of the person who designs the pneumatic system or decides its specifications.**
Since the products specified here are used in various operating conditions, their compatibility for the specific pneumatic system must be based on specifications or after analysis and/or tests to meet your specific requirements.
- Only trained personnel should operate pneumatically operated machinery and equipment.**
Compressed air can be dangerous if an operator is unfamiliar with it. Assembly, handling or repair of pneumatic systems should be performed by trained and experienced operators.
- Do not service machinery/equipment or attempt to remove component until safety is confirmed.**
 - Inspection and maintenance of machinery/equipment should only be performed after confirmation of safe locked-out control positions.
 - When equipment is to be removed, confirm the safety process as mentioned above. Switch off air and electrical supplies and exhaust all residual compressed air in the system.
 - Before machinery/equipment is re-started, ensure all safety measures to prevent sudden movement of cylinders etc. (Bleed air into the system gradually to create backpressure, i.e. incorporate a soft-start valve).
- Contact SMC if the product is to be used in any of the following conditions:**
 - Conditions and environments beyond the given specifications, or if product is used outdoors.
 - Installations in conjunction with atomic energy, railway, air navigation, vehicles, medical equipment, food and beverage, recreation equipment, emergency stop circuits, press applications, or safety equipment.
 - Applications, which have the possibility of having negative effects on people, properties or animals, requiring special safety analysis.

1.2 Conformity to standard

This product is certified to and complies with the following standards:

- Directive 94/9/EC
- EN 13463-1:2001
Non-electrical equipment for potentially explosive atmospheres
Part 1: Basic method and requirements

2 INTENDED CONDITIONS OF USE

Fluid	Air	
Max. operating pressure	0.7 MPa	
Min. operating pressure	∅6, ∅10, ∅15	0.15 MPa
pressure	∅20, ∅25, ∅32	0.1 MPa
Ambient and fluid temperature	-10 to 60 °C	
Lubrication	Not required	
Operating piston speed	50 to 500 mm/s	
Cushion	Rubber bumper	
Allowable kinetic energy	∅6	0.02 J
	∅10	0.07 J
	∅15	0.09 J
	∅20	0.18 J
	∅25	0.24 J
	∅32	0.49 J
Explosive atmosphere	Gas and Dust	
Zone	1, 21, 2 and 22	

WARNING

- In case the kinetic energy exceeds the value given in the table, please contact SMC.
- Do not use in case of heavy dusty environment where dust can penetrate into the cylinder and dry the grease.

2.1 Production batch code

The production batch code printed on the label indicates the month and year of production as per the following table:

Production batch codes									
Year	Month								
	2003	2004	2005	...	2021	2022	2023	...	
Jan	O	HO	IO	JO	...	ZO	AO	BO	...
Feb	P	HP	IP	JP	...	ZP	AP	BP	...
Mar	Q	HQ	IQ	JQ	...	ZQ	AQ	BQ	...
Apr	R	HR	IR	JR	...	ZR	AR	BR	...
May	S	HS	IS	JS	...	ZS	AS	BS	...
Jun	T	HT	IT	JT	...	ZT	AT	BT	...
Jul	U	HU	IU	JU	...	ZU	AU	BU	...
Aug	V	HV	IV	JV	...	ZV	AV	BV	...
Sep	W	HW	IW	JW	...	ZW	AW	BW	...
Oct	X	HX	IX	JX	...	ZX	AX	BX	...
Nov	Y	HY	IY	JY	...	ZY	AY	BY	...
Dec	Z	HZ	IZ	JZ	...	ZZ	AZ	BZ	...

3 INSTALLATION

WARNING

- Do not install unless the safety instructions have been read and understood.

3.1 Environment

WARNING

- Do not use in an environment where the product is directly exposed to corrosive gases, chemicals, salt water, water or steam.
- The product should not be exposed to prolonged sunlight such to generate surface temperature higher than the value given for temperature class. Use a protective cover.
- Do not mount the product in a location where it is subjected to strong vibrations such to generate surface temperature higher than the value given for temperature class. Avoid any kind of shock or impact.
- Do not mount the product in a location where it is exposed to radiant heat.

3.2 Piping

WARNING

- Before piping clean away all chips, cutting oil, dust, etc.
- When installing piping or fitting into a port, in case of using sealant type fittings, ensure that sealant material does not enter the port inside. When using seal tape, leave 1.5 to 2 threads exposed on the end of pipe/fitting.

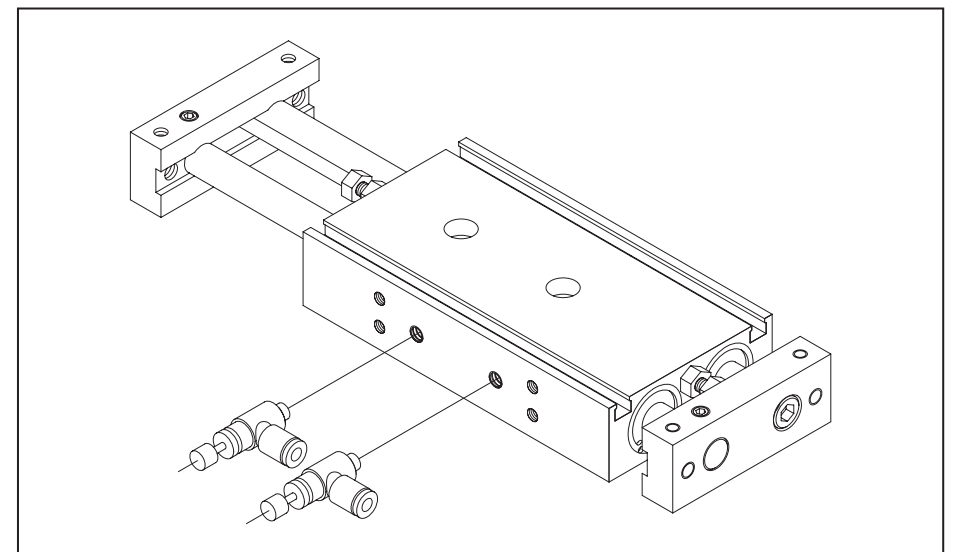

Model	Port size
55-CXS#6	M5 x 0.8
55-CXS#10	
55-CXS#15	
55-CXS#20	
55-CXS#25TF	G 1/8
55-CXS#32TF	

3.3 Electrical connection

WARNING

Provide grounding connection to the actuator to avoid any spark arising from potential differences.

3.4 Lubrication

CAUTION

Our products have been lubricated for life at manufacturer, and do not require lubrication in service.

If a lubricant is used in the system, use turbine oil Class 1(no additive), ISO VG32. Once lubricant is used in the system, lubrication must be continued because the original lubricant applied during manufacturing will be washed away.

4 MAINTENANCE

⚠ WARNING

- Not following proper procedures could cause the product to malfunction and could lead to damage to the equipment or machine.
- If handled improperly, compressed air can be dangerous. Assembly, handling and repair of pneumatic system should be performed by qualified personnel only.
- Drain: remove condensate from the filter bowl on a regular basis.
- Shut down before maintenance: before attempting any kind of maintenance make sure the supply pressure is shut off and all residual air pressure is released from the system to be worked on.
- Start up after maintenance: apply operating pressure and power to the equipment and check for proper operation and possible air leaks. If operation is abnormal, please verify product set-up parameters.
- Do not make any modification to the product.
- Periodically check the rod surface, the rod seal and the cylinder tube external surface. Any damage in these components could increase friction and lead to dangerous conditions. Replace the whole actuator if any of these conditions should appear.
- Replace the seals, when air leakage is above allowable value given in the table below.

Internal leakage	10 cm ³ /min (ANR)
External leakage	5 cm ³ /min (ANR)

Seals replacement

⚠ WARNING

Use only original SMC seal kits, given in the table below.

Series	Kit no.	Series	Kit no.
CXSWM6	CXSWM6-PS	CXSWL6	CXSWL6-PS
CXSWM10	CXSWM10APS	CXSWL10	CXSWL10BPS
CXSWM15	CXSWM15-PS	CXSWL15	CXSWL15APS
CXSWM20	CXSWM20-PS	CXSWL20	CXSWL20APS
CXSWM25	CXSWM25-PS	CXSWL25	CXSWL25APS
CXSWM32	CXSWM32-PS	CXSWL32	CXSWL32APS

Procedure

Disassemble the cylinder, remove the old grease and place all the parts on a clean cloth in a clean environment. Remove the O-ring, rod seal, piston seal.

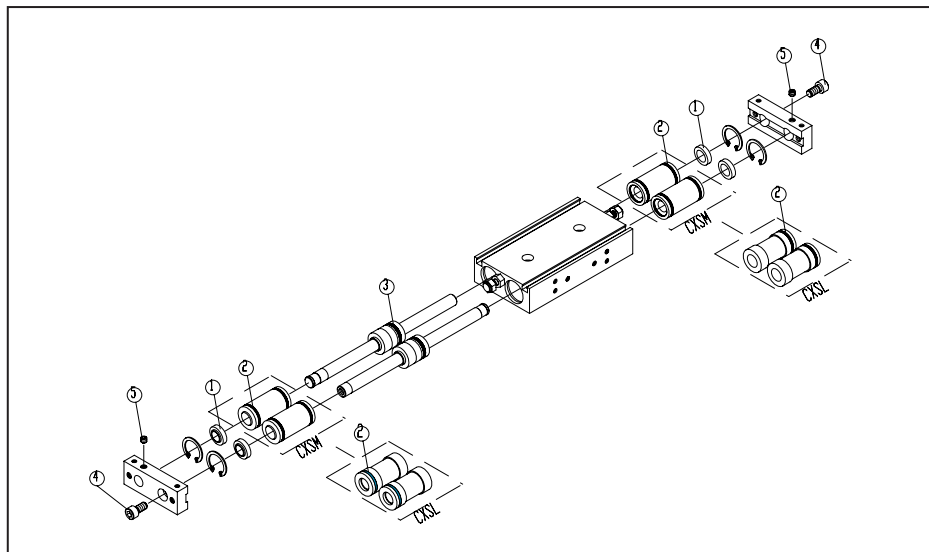

1	Rod seal
2	O-ring
3	Piston Seal
4	Hexagon socket head cap bolt
5	Hexagon socket head set screw

Lubricate the parts using "Mitsubishi Multi Purpose Grease 2" or "Lithium Type Grease JIS 2".

Apply lubricant to:

- rod seal
- rod seal groove on the rod cover
- piston outer surface
- piston seal groove
- piston seal inner and outer surface
- piston rod surface
- tube inner surface

The amount of lubricant, to be applied, is given in the following table:

Bore size (mm)	Amount of lubricant (g)
6	0.3~0.5
10	0.5~1
15	1~1.5
20	1.5~2
25	2~2.5
32	2.5~3

Reassembly should be done in the following order:

(One side) Rod cover assembly/ball pushing assembly → Snap ring on the rod cover side → Piston rod assembly → (Other side) Rod cover assembly/ball pushing assembly → Snap ring on the rod cover side → Plate.

Then, tighten the hexagon socket head cap bolt first and then the hexagon socket head set screw. Use the following torque for tightening the hexagon socket head cap bolt and hexagon socket head set screw.

Bore size (mm)	Tightening torque for hexagon Socket head cap bolt (Nm)	Tightening torque for hexagon socket head set screw (Nm)
6	1~1.5	0.5~0.8
10	3~4	3~4
15	3~4	7.5~9
20	8~10	9~11
25	8~10	9~11
32	12.5~16.5	19.6~29.4

Check for cylinder smooth movement and for air leakage.

5 LIMITATIONS OF USE

⚠ WARNING

- Do not exceed any of the specifications laid out in section 2 of this document or the specific product catalogue.

⚠ DANGER

- Air equipment has standard air leakage within certain limits.
- Do not use this equipment when the air itself can lead to explosion danger.

⚠ CAUTION

- Do not install and use this equipment in case of vibration such to lead to equipment failure. Contact SMC for this specific situation.

⚠ WARNING

- External impact on the cylinder body could result in spark and/or cylinder damage. Avoid any application where foreign objects can hit the cylinder. In such situations install suitable guard to prevent such impacts.
- Use only ATEX certified auto-switch. Order them separately.
- Do not use in presence of strong magnetic fields, which could generate surface temperature higher than the value given for the temperature class.

6 EUROPEAN CONTACT LIST

SMC Corporation

Country	Telephone	Country	Telephone
Austria	(43) 2262-62 280	Italy	(39) 02-92711
Belgium	(32) 3-355 1464	Netherlands	(31) 20-531 8888
Czech Republic	(420) 5-414 24611	Norway	(47) 67 12 90 20
Denmark	(45) 70 25 29 00	Poland	(48) 22-548 50 85
Finland	(358) 9-859 580	Portugal	(351) 22 610 89 22
France	(33) 1-64 76 1000	Spain	(34) 945-18 4100
Germany	(49) 6103 4020	Sweden	(46) 8-603 0700
Greece	(30) 1- 342 6076	Switzerland	(41) 52-396 3131
Hungary	(36) 1-371 1343	Turkey	(90) 212 221 1512
Ireland	(351) 1-403 9000	United Kingdom	(44) 1908-56 3888

Websites

SMC Corporation	www.smcworld.com
SMC Europe	www.smceu.com