



Instructions and Maintenance Manual

Mechanically Jointed Rodless Cylinder
Series 55-MY1B



II 2G c 75°C (T6) Ta 5°C to 40°C
95°C (T5) Ta 40°C to 60°C

Read this manual before using this product.

For future reference, please keep this manual in a safe place.

The information within this document is to be used by pneumatically trained personnel only.

This manual should be read in conjunction with the current catalogue.

Marking description	
II 2G c	75°C (T6) Ta 5°C to 40°C 95°C (T5) Ta 40°C to 60°C
Group II	
Category 2	
Suitable for Gas environment	
Type of protection "constructional safety"	
Max surface temperature 75°C and temperature class T6 when ambient temperature is from 5°C to 40°C	
Max surface temperature 95°C and temperature class T5 when ambient temperature is from 40°C to 60°C	

1 SAFETY RECOMMENDATION

1.1 General recommendation

These safety instructions are intended to prevent a hazardous situation and/or equipment damage. These instructions indicate the level of potential hazard by label of "Caution", "Warning" or "Danger". To ensure safety, be sure to observe ISO4414 (Note1), JIS B 8370 (Note2) and other safety practices.

Note1: ISO 4414: Pneumatic fluid power - General rules relating to systems.

Note2: JIS B 8370: Pneumatic system axiom.



CAUTION: Operator error could result in injury or equipment damage.



WARNING: Operator error could result in injury or loss of life.



DANGER: In extreme conditions, there is possible result of serious injury or loss of life.



WARNING

- The compatibility of pneumatic equipment is the responsibility of the person who designs the pneumatic system or decides its specifications.**

Since the products specified here are used in various operating conditions, their compatibility for the specific pneumatic system must be based on specifications or after analysis and/or tests to meet your specific requirements.

- Only trained personnel should operate pneumatically operated machinery and equipment.**

Compressed air can be dangerous if an operator is unfamiliar with it. Assembly, handling or repair of pneumatic systems should be performed by trained and experienced operators.

- Do not service machinery/equipment or attempt to remove component until safety is confirmed.**

- Inspection and maintenance of machinery/equipment should only be performed after confirmation of safe locked-out control positions.
- When equipment is to be removed, confirm the safety process as mentioned above. Switch off air and electrical supplies and exhaust all residual compressed air in the system.
- Before machinery/equipment is re-started, ensure all safety measures to prevent sudden movement of cylinders etc. (Bleed air into the system gradually to create backpressure, i.e. incorporate a soft-start valve).

- Contact SMC if the product is to be used in any of the following conditions:**

- Conditions and environments beyond the given specifications, or if product is used outdoors.
- Installations in conjunction with atomic energy, railway, air navigation, vehicles, medical equipment, food and beverage, recreation equipment, emergency stop circuits, press applications, or safety equipment.
- Applications, which have the possibility of having negative effects on people, properties or animals, requiring special safety analysis.

1.2 Conformity to standard

This product is certified to and complies with the following standards:

- Directive 94/9/EC
- EN 13463-1:2001
Non-electrical equipment for potentially explosive atmospheres
Part 1: Basic method and requirements

1.3 Specific recommendations



WARNING

- Intermediate stops.**

When intermediate stopping of a cylinder piston is performed with a 3 position closed centre type directional control valve, it is difficult to achieve stopping positions as accurate and minute as with hydraulic pressure due to the compressibility of air. Furthermore, since valves and cylinders, etc., are not guaranteed for zero air leakage, and it is not possible to hold a stopped position, do not use for this purpose. In case it is necessary to hold a stopped position, select equipment and design circuits to prevent movement.



CAUTION

- Provide intermediate supports for long stroke cylinders.**

Provide intermediate supports for cylinders with long strokes to prevent bending of the tube, and deflection due to vibration and external loads, etc.

2 INTENDED CONDITIONS OF USE

Fluid		Air
Max. operating pressure		0.8 MPa
Min. operating pressure	∅10	0.2 MPa
pressure	∅16~∅100	0.1 MPa
Ambient and fluid temperature		5 to 60 °C
Operating piston speed	∅10	100 to 500 mm/s
	∅16~∅100	100 to 1000 mm/s
Cushion	∅10	Rubber bumper
	∅16~∅100	Air cushion
Allowable kinetic energy	∅10	0.02 J
	∅16	0.6 J
	∅20	1 J
	∅25	1.7 J
	∅32	3.4 J
	∅40	6.2 J
	∅50	9.6 J
	∅63	17 J
	∅80	35 J
	∅100	54 J
Explosive atmosphere		Gas
Zone		1 and 2



WARNING

- In case the kinetic energy exceeds the value given in the table, please contact SMC.
- Do not use in a heavily dusty environment where dust can penetrate into the cylinder and dry the grease.

2.1 Production batch code

The production batch code printed on the label indicates the month and year of production as per the following table:

Production batch codes									
Year	Month								
	2003	2004	2005	...	2021	2022	2023	...	
Jan	O	HO	IO	JO	...	ZO	AO	BO	...
Feb	P	HP	IP	JP	...	ZP	AP	BP	...
Mar	Q	HQ	IQ	JQ	...	ZQ	AQ	BQ	...
Apr	R	HR	IR	JR	...	ZR	AR	BR	...
May	S	HS	IS	JS	...	ZS	AS	BS	...
Jun	T	HT	IT	JT	...	ZT	AT	BT	...
Jul	U	HU	IU	JU	...	ZU	AU	BU	...
Aug	V	HV	IV	JV	...	ZV	AV	BV	...
Sep	W	HW	IW	JW	...	ZW	AW	BW	...
Oct	X	HX	IX	JX	...	ZX	AX	BX	...
Nov	Y	HY	IY	JY	...	ZY	AY	BY	...
Dec	Z	HZ	IZ	JZ	...	ZZ	AZ	BZ	...

3 INSTALLATION



WARNING

- Do not install unless the safety instructions have been read and understood.



WARNING

- Do not apply strong impact or excessive moment to the slide table (slider).**
The slide table (slider) is supported by precision bearings (MY1H) or resin bearings (MY1B, MY1M). Therefore, do not apply strong impacts or excessive moment, etc., when mounting work pieces.
- Align carefully when connecting to a load having an external guide mechanism.**
Mechanically jointed rodless cylinders can be used with a direct load within the allowable range for each type of guide, but careful alignment is necessary when connecting to a load having an external guide mechanism. As the stroke becomes longer, variations in the center axis become larger. Consider using a connection method (floating mechanism) that is able to absorb these variations. Furthermore, use the special floating brackets which have been designed for series MY1B.
- Do not scratch or gouge the cylinder tube by striking or grasping it with other objects.**
Cylinder bores are manufactured to precise tolerances therefore even a slight deformation may cause malfunction.
- Do not use until you can verify that equipment can operate properly.**
Verify correct mounting by suitable function and leakage inspections after compressed air and power are connected following mounting, maintenance or conversions.
- Instruction Manual.**
The product should be mounted and operated after thoroughly reading the manual and understanding its contents. Keep the instruction manual where it can be referred to as needed.

3.1 Environment



WARNING

- Do not use in an environment where the product is directly exposed to corrosive gases, chemicals, salt water, water or steam.
- The product should not be exposed to prolonged sunlight such to generate surface temperature higher than the value given for temperature class. Use a protective cover.
- Do not mount the product in a location where it is subjected to strong vibrations such to generate surface temperature higher than the value given for temperature class. Avoid any kind of shock or impact.
- Do not mount the product in a location where it is exposed to radiant heat.
- Provide a cover or other protection in dusty locations or where water, oil, etc., splash on the equipment. The cylinder may malfunction if operated in a location with a lot of dirt, water droplets, coolant or paper dust, etc. Provide a cover or other protective measure.

3.2 Piping



WARNING

- Before piping clean away all chips, cutting oil, dust, etc.
- When installing piping or fitting into a port, in case of using sealant type fittings, ensure that sealant material does not enter the port inside. When using seal tape, leave 1.5 to 2 threads exposed on the end of pipe/fitting.

Bore size (mm)	Port Size
10	M5 x 0.8
16	
20	
25	Rc, G or NPT 1/8
32	Rc, G or NPT 1/4
40	
50	
63	Rc, G or NPT 3/8
80	Rc, G or NPT 1/2
100	

3.3 Electrical connection



WARNING

Provide grounding connection to the actuator to avoid any spark arising from potential differences.

3.4 Mounting accessories

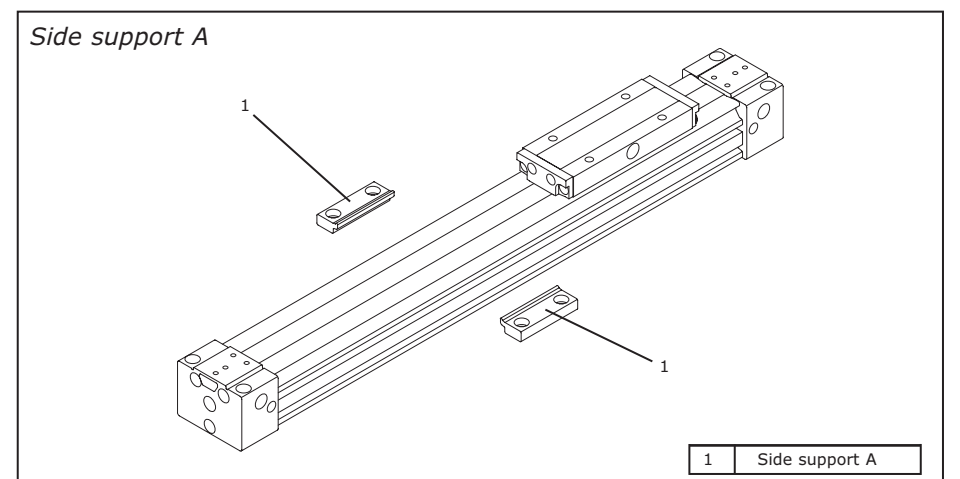

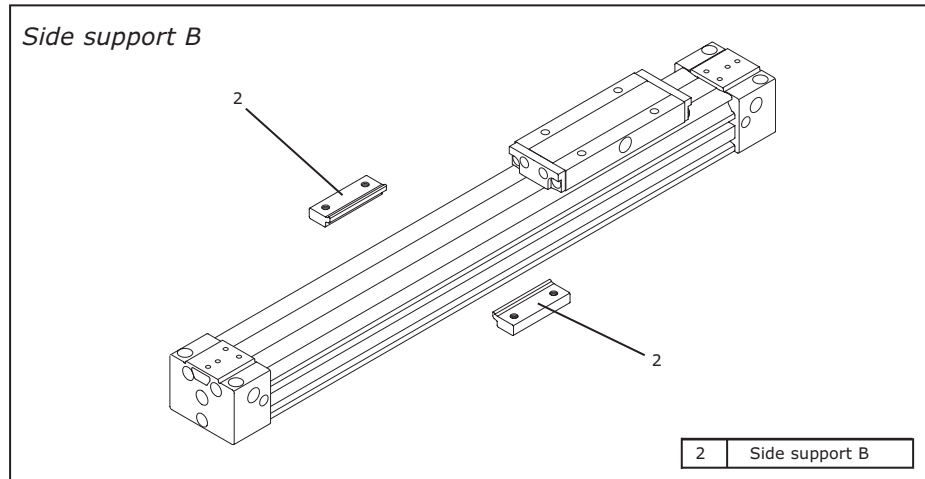

When replacing side support, use the hexagonal socket head cap screws of the following sizes, and the hexagon wrenches shown below.

Bore size (mm)	Cap screw size		Width across flats (mm)	
	Side support A	Side support B	Side support A	Side support B
10	M3	M4	2.5	3
16	M4	M5	3	4
20				
25	M5	M6	4	5
32				
40	M6	M8	5	6
50				
63	M8	M10	6	8
80				
100	M10	M12	8	10

3.5 Lubrication

CAUTION

Our products have been lubricated for life at manufacturer, and do not require lubrication in service.

If a lubricant is used in the system, use turbine oil Class 1(no additive), ISO VG32. Once lubricant is used in the system, lubrication must be continued because the original lubricant applied during manufacturing will be washed away.

4 AIR-CUSHION ADJUSTMENT

For air-cushion adjustment, tighten or loosen the cushion valve using a hexagon socket wrench or a flat head screwdriver (excluding ø10).

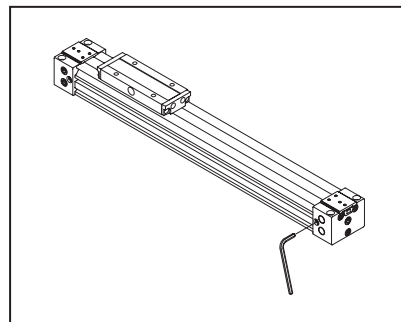

Bore size (mm)	Head	Width across flats (mm)
16	Hexagon socket	1.5
20		
25		
32		
40	Hexagon socket	2.5
50		
63		
80	Slotted	3
100		
100	Slotted	2

5 MAINTENANCE

WARNING

- Not following proper procedures could cause the product to malfunction and could lead to damage to the equipment or machine.
- If handled improperly, compressed air can be dangerous. Assembly, handling and repair of pneumatic system should be performed by qualified personnel only.
- Drain: remove condensate from the filter bowl on a regular basis.
- Shut down before maintenance: before attempting any kind of maintenance make sure the supply pressure is shut off and all residual air pressure is released from the system to be worked on.

- Start up after maintenance: apply operating pressure and power to the equipment and check for proper operation and possible air leaks. If operation is abnormal, please verify product set-up parameters.
- Do not make any modification to the product.

Replacement of dust seal band

WARNING

The dust seal band is the only customer replaceable part. For replacement of other parts, please return the product to SMC for servicing.

Use only original SMC dust seal band, given in the table below.

Bore size (mm)	Replacement part no.	Standard length
10	MY10-16B-stroke	Stroke+110
16	MY16-16B-stroke	Stroke+160
20	MY20-16B-stroke	Stroke+200
25	MY25-16B-stroke	Stroke+182
32	MY32-16B-stroke	Stroke+228
40	MY40-16B-stroke	Stroke+272
50	MY50-16B-stroke	Stroke+328
63	MY63-16B-stroke	Stroke+382
80	MY80-16B-stroke	Stroke+544
100	MY100-16B-stroke	Stroke+634

Procedure

Disassemble the cylinder, remove the old grease and place all the parts on a clean cloth in a clean environment. The following flat head screwdriver or hexagon socket wrench shall be used to loosen the set screws:

Bore size (mm)	Head	Width across flats (mm)
10	Slotted	0.25
16	Hexagon socket	1.5
20		
25		
32		
40		
50		
63		
80		
100		

The following screwdriver or hexagon socket wrenches shall be used to loosen the cross recessed binding head screws and the hexagon socket button bolt.

Bore size (mm)	Head	Width across recess and across flats (mm)
10	Cross recessed	2.2
16	Hexagon socket	2
20		
25		
32		
40		
50	Hexagon socket	1.5
63		
80		
100	Hexagon socket	3

Remove the old dust seal band, scrapers and if necessary, bearings and side scrapers.

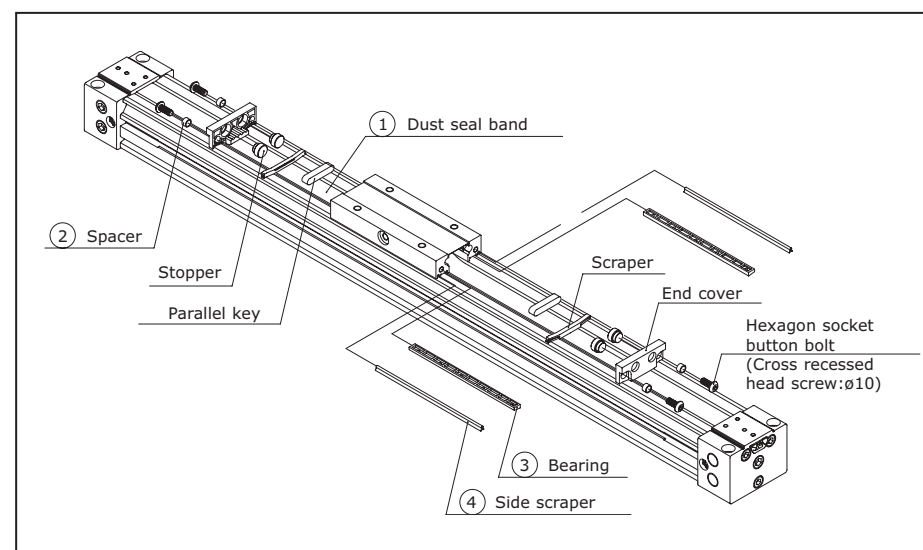

1	Dust seal band
2	Scraper
3	Bearing
4	Side scraper

Lubricate the parts using "Mitsubishi Multi Purpose Grease 2" or "Lithium Type Grease JIS 2".

Apply lubricant to:

- Dust seal band inner and outer surface
- scrapers
- bearings
- side scrapers
- tube top surface

The cylinder is assembled in the following order: bearings, dust seal band, side scraper, parallel key, scraper, stopper, spacer and end cover. Tighten the cross recessed binding head screws or the hexagon socket button bolt according to the torque values given.

Bore size (mm)	Torque Nm
10	0.15
16	0.3
20	
25	
32	0.7
40	
50	1.5
63	
80	
100	

Finally tighten the two set screws at each side with tightening torque of 0.1 Nm.

Check for cylinder smooth movement and for air leakage.

6 LIMITATIONS OF USE

WARNING

- Do not exceed any of the specifications laid out in section 2 of this document or the specific product catalogue.

DANGER

- Air equipment has standard air leakage within certain limits.
- Do not use this equipment when the air itself can lead to explosion danger.

CAUTION

- Do not install and use this equipment in case of vibration such to lead to equipment failure. Contact SMC for this specific situation.

WARNING

- External impact on the cylinder body could result in spark and/or cylinder damage. Avoid any application where foreign objects can hit the cylinder. In such situations install suitable guard to prevent such impacts.
- Use only ATEX certified auto-switch. Order them separately.
- Do not use in presence of strong magnetic fields, which could generate surface temperature higher than the value given for the temperature class.

7 EUROPEAN CONTACT LIST

SMC Corporation

Country	Telephone	Country	Telephone
Austria	(43) 2262-62 280	Italy	(39) 02-92711
Belgium	(32) 3-355 1464	Netherlands	(31) 20-531 8888
Czech Republic	(420) 5-414 24611	Norway	(47) 67 12 90 20
Denmark	(45) 70 25 29 00	Poland	(48) 22-548 50 85
Finland	(358) 9-859 580	Portugal	(351) 22 610 89 22
France	(33) 1-64 76 1000	Spain	(34) 945-18 4100
Germany	(49) 6103 4020	Sweden	(46) 8-603 0700
Greece	(30) 1- 342 6076	Switzerland	(41) 52-396 3131
Hungary	(36) 1-371 1343	Turkey	(90) 212 221 1512
Ireland	(351) 1-403 9000	United Kingdom	(44) 1908-56 3888

Websites

SMC Corporation	www.smcworld.com
SMC Europe	www.smceu.com