



## Instructions and Maintenance Manual

Rotary Actuator  
Series 56-C(D)RBU2



II 3G

100°C (T5) Ta 5°C to 40°C  
120°C (T4) Ta 40°C to 60°C

Read this manual before using this product.

For future reference, please keep this manual in a safe place.

The information within this document is to be used by pneumatically trained personnel only.

This manual should be read in conjunction with the current catalogue.

Marking description	
II 3G	100°C (T5) Ta 5°C to 40°C 120°C (T4) Ta 40°C to 60°C
Group II	
Category 3	
Suitable for Gas environment	
Max surface temperature 100°C and temperature class T5 when ambient temperature is from 5°C to 40°C	
Max surface temperature 120°C and temperature class T4 when ambient temperature is from 40°C to 60°C	

## 1 SAFETY RECOMMENDATION

### 1.1 General recommendation

These safety instructions are intended to prevent a hazardous situation and/or equipment damage. These instructions indicate the level of potential hazard by label of "Caution", "Warning" or "Danger". To ensure safety, be sure to observe ISO4414 (Note1), JIS B 8370 (Note2) and other safety practices.

Note1: ISO 4414: Pneumatic fluid power - General rules relating to systems. Note 2: JIS B 8370: Pneumatic system axiom.

	<b>CAUTION:</b> Operator error could result in injury or equipment damage.
	<b>WARNING:</b> Operator error could result in injury or loss of life.
	<b>DANGER:</b> In extreme conditions, there is possible result of serious injury or loss of life.

### WARNING

- The compatibility of pneumatic equipment is the responsibility of the person who designs the pneumatic system or decides its specifications.**  
Since the products specified here are used in various operating conditions, their compatibility for the specific pneumatic system must be based on specifications or after analysis and/or tests to meet your specific requirements.
- Only trained personnel should operate pneumatically operated machinery and equipment.**  
Compressed air can be dangerous if an operator is unfamiliar with it. Assembly, handling or repair of pneumatic systems should be performed by trained and experienced operators.
- Do not service machinery/equipment or attempt to remove component until safety is confirmed.**
  - Inspection and maintenance of machinery/equipment should only be performed after confirmation of safe locked-out control positions.
  - When equipment is to be removed, confirm the safety process as mentioned above. Switch off air and electrical supplies and exhaust all residual compressed air in the system.
  - Before machinery/equipment is re-started, ensure all safety measures to prevent sudden movement of cylinders etc. (Bleed air into the system gradually to create backpressure, i.e. incorporate a soft-start valve).
- Contact SMC if the product is to be used in any of the following conditions:**
  - Conditions and environments beyond the given specifications, or if product is used outdoors.
  - Installations in conjunction with atomic energy, railway, air navigation, vehicles, medical equipment, food and beverage, recreation equipment, emergency stop circuits, press applications, or safety equipment.
  - Applications, which have the possibility of having negative effects on people, properties or animals, requiring special safety analysis.

### 1.2 Conformity to standard

This product is certified to and complies with the following standards:

- Directive 94/9/EC
- EN 13463-1:2001  
Non-electrical equipment for potentially explosive atmospheres  
Part 1: Basic method and requirements

## 2 INTENDED CONDITIONS OF USE

Size	10	15	20	30	40
Vane style	Single Vane				
Operating fluid	Air (Non-lube)				
Max. operating pressure	0.7MPa			1.0MPa	
Min. operating pressure	0.2MPa	0.15MPa			
Ambient temp. and operating fluid temp.	5~60°C				
Rotation angle (°)	90, 180, 270				
Port position	on body side or axial direction ports				
Port size	Body side	M5x0.8			
	Axial direction	M3x0.5	M5x0.8		
Supporting style	Basic type				
Output (Nm)*	0.12	0.32	0.7	1.83	3.73
Explosive atmosphere	Gas				
Zone	2				

\*) Indicates output with operating pressure at 0.5MPa

Size	10	15	20	30	40
Vane style	Double Vane				
Operating fluid	Air (Non-lube)				
Max. operating pressure	0.7MPa			1.0MPa	
Min. operating pressure	0.2MPa	0.15MPa			
Ambient temp. and operating fluid temp.	5~60°C				
Rotation angle (°)	90, 100				
Port position	on body side or axial direction ports				
Port size	Body side	M5x0.8			
	Axial direction	M3x0.5	M5x0.8		
Supporting style	Basic type				
Output (Nm)*	0.25	0.65	1.45	3.7	7.59
Explosive atmosphere	Gas				
Zone	2				

\*) Indicates output with operating pressure at 0.5MPa

### WARNING

- Select a speed within the product's allowable kinetic energy limit.
- In case the kinetic energy exceeds the value given in the table, please contact SMC.
- Provide a shock absorber if the kinetic energy of the system connected to the product exceeds the allowable value.
- Do not generate any impacts between metal parts when the shock absorber is set up.
- Do not stop or hold the product at the mid point by keeping air pressure in the product.
- If the product is used at low speed below the specified speed adjustment range, it could cause the product to stick slip, or to stop its movement.

Size	Allowable kinetic energy (mJ)				Safe adjustment range of rotating time
	Single Vane		Double Vane		
	No rubber cushion	Rubber cushion	No rubber cushion	Rubber cushion	Rotation time (s/90)
10	0.15	-	0.3	-	0.03~0.3
15	-	1	-	1.2	
20	-	3	-	3.3	
30	-	20	-	20	0.04~0.3
40	-	40	-	40	0.07~0.5

### 2.1 Production batch code

The production batch code printed on the label indicates the month and year of production as per the following table:

Production batch codes									
Month	Year	2003	2004	2005	...	2021	2022	2023	...
		H	I	J	...	Z	A	B	...
Jan	O	HO	IO	JO	...	ZO	AO	BO	...
Feb	P	HP	IP	JP	...	ZP	AP	BP	...
Mar	Q	HQ	IQ	JQ	...	ZQ	AQ	BQ	...
Apr	R	HR	IR	JR	...	ZR	AR	BR	...
May	S	HS	IS	JS	...	ZS	AS	BS	...
Jun	T	HT	IT	JT	...	ZT	AT	BT	...
Jul	U	HU	IU	JU	...	ZU	AU	BU	...
Aug	V	HV	IV	JV	...	ZV	AV	BV	...
Sep	W	HW	IW	JW	...	ZW	AW	BW	...
Oct	X	HX	IX	JX	...	ZX	AX	BX	...
Nov	Y	HY	IY	JY	...	ZY	AY	BY	...
Dec	Z	HZ	IZ	JZ	...	ZZ	AZ	BZ	...

## 3 INSTALLATION

### WARNING

- Do not install unless the safety instructions have been read and understood.
- Before operating the product by supplying air pressure, take appropriate measures to prevent the equipment from rotating unnecessarily.
- Do not modify the product.
- Do not enlarge the fixed throttle by modifying the pipe connectors.
- If shaft couplings are to be used, use those with angular freedom.

### 3.1 Environment

#### WARNING

- Do not use in an environment where the product is directly exposed to corrosive gases, chemicals, salt water, water or steam.
- Do not use the rotary actuator in an area that contains a large amount of dust, or an area in which water or oil could be splashed on the rotary actuator.
- The product should not be exposed to prolonged sunlight such to generate surface temperature higher than the value given for temperature class. Use a protective cover.
- Do not mount the product in a location where it is subjected to strong vibrations such to generate surface temperature higher than the value given for temperature class. Avoid any kind of shock or impact.
- Do not mount the product in a location where it is exposed to radiant heat.

### 3.2 Piping

#### WARNING

- Before piping clean away all chips, cutting oil, dust, etc.
- When installing piping or fitting into a port, in case of using sealant type fittings, ensure that sealant material does not enter the port inside. When using seal tape, leave 1.5 to 2 threads exposed on the end of pipe/fitting.

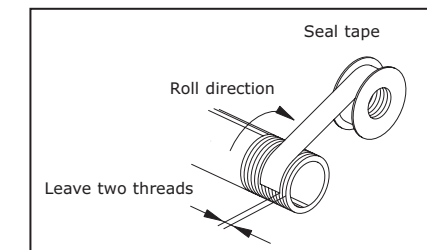

### 3.3 Electrical connection

#### WARNING

- Provide grounding connection to the actuator to avoid any spark arising from potential differences.

**3.4 Mounting**

**Restrictions on the load applied to the shaft**

A static load, up to the values shown in the table below, can be applied to the actuator shaft, provided that a dynamic load is not generated. However, applications in which a load is directly applied to the shaft should be avoided as far as possible.

Size	Allowable Load (N)	
	Load direction	
	F <sub>sa</sub> & F <sub>sb</sub>	F <sub>r</sub> *
10	9.8	14.7
15	9.8	14.7
20	19.6	24.5
30	24.5	29.4
40	40.0	60.0

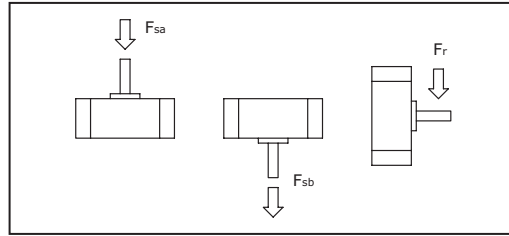

(\* ) The point of application of the force Fr is the centre of the shaft flat or of the longer dimension of the key.

In operating conditions, radial and axial load should be avoided. In order to improve operating conditions and to avoid direct loads on the shaft, a method such as that shown in the drawing below is recommended.

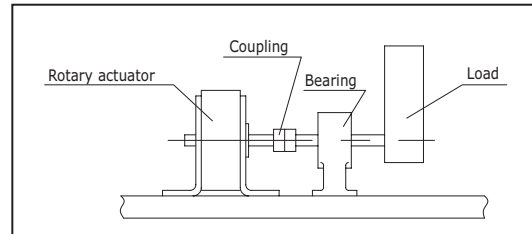
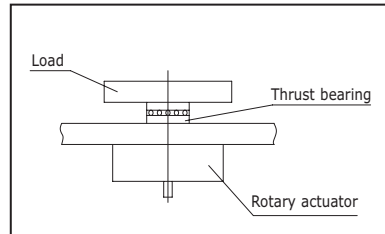

**Axis fitting instruction**

Alignment of the rotary actuator and the mating axis is necessary when the rotary actuator is used with its axis lengthened. If misaligned, partial load becomes high and the axis is applied with excessive bending moment. Under this condition, stable operation is not possible and the axis could be damaged. In this case, flexible joint (as specified by JIS) becomes necessary.

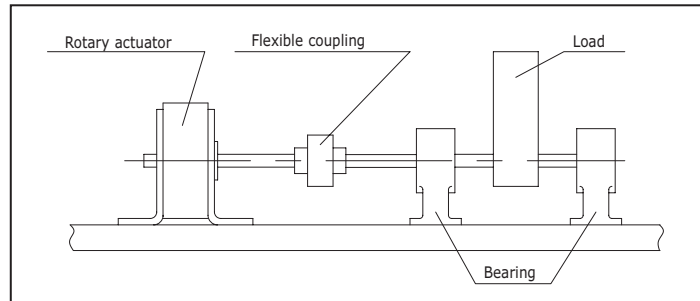

**Mounting types**

Direct mounting in the axial, vertical or side direction is possible.

Size	Body tapped	Body through-hole
10	M3	ø 3.5
15	M4	ø 4.5
20	M4	ø 4.5
30	M5	ø 5.5
40	M5	ø 5.5

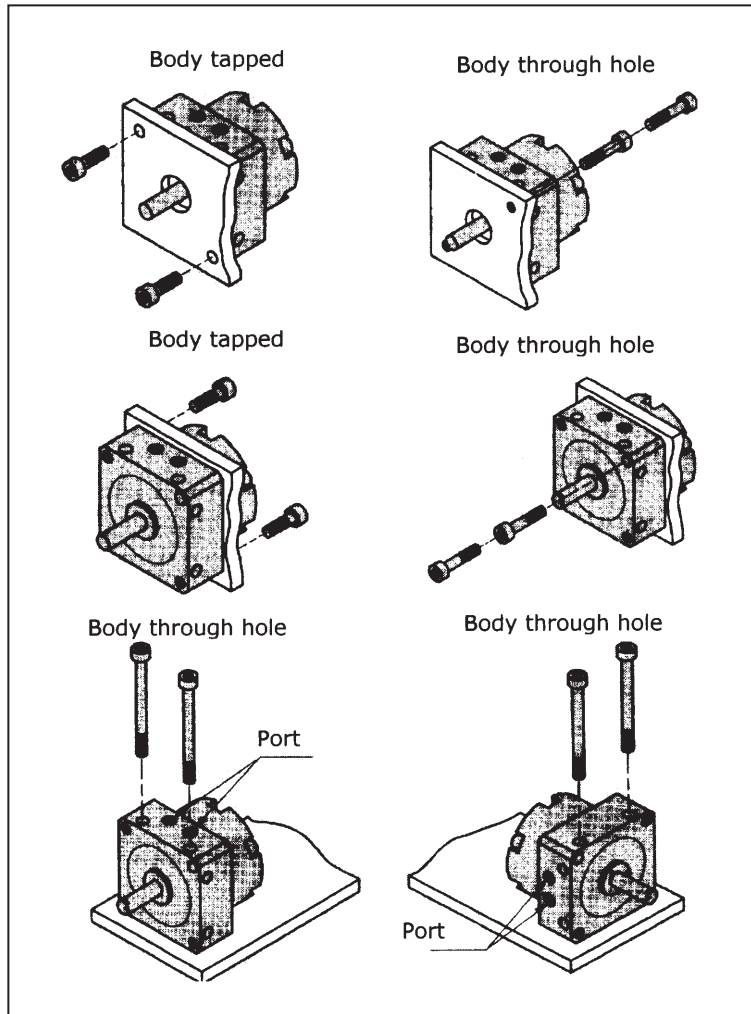

**3.5 Piping and operating direction**

Figure shows piping ports of the rotary actuator. Table shows the port size.

Size	Port size
10	M3x0.5, M5x0.8
15	
20	
30	M5x0.8
40	

**CRBU2**

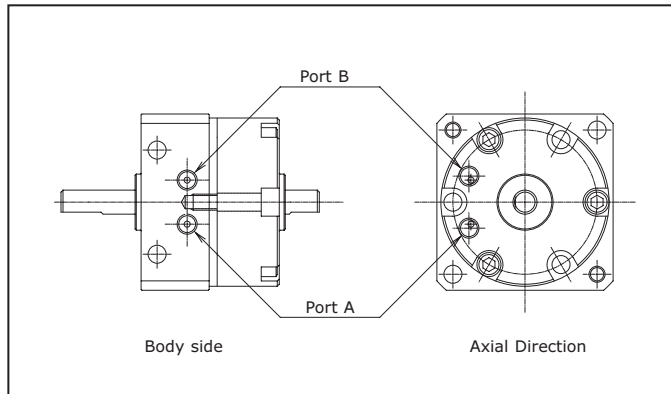

**CDRBU2**

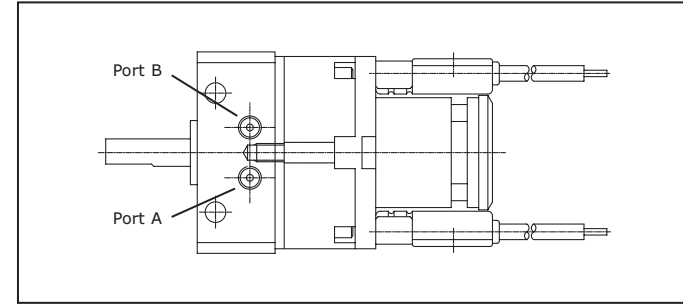

The rotary actuator port is equipped with a fixed size orifice. Do not enlarge the hole. Enlarging the hole will increase the operation speed of the actuator and the consequent impact at the end of each stroke could lead to the actuator failure.

The axis rotates clockwise when pressurized from A port. Perform followings before piping.

**Operating air**

Air supplied to the rotary actuator shall be cleaned by the filter. CRBU2 series is lubrication free.

**3.6 Lubrication**

**CAUTION**

- Our products have been lubricated for life at manufacturer, and do not require lubrication in service.
- If a lubricant is used in the system, use turbine oil Class 1(no additive), ISO VG32. Once lubricant is used in the system, lubrication must be continued because the original lubricant applied during manufacturing will be washed away.

**4 MAINTENANCE**

Do not dismantle the product. Products dismantled and re-assembled by end-users are not covered by guarantee. Please send it back to the factory when exchange and repairing of parts are necessary.

**5 LIMITATIONS OF USE**

**WARNING**

- Do not exceed any of the specifications laid out in section 2 of this document or the specific product catalogue.
- Do not modify the product.

**DANGER**

- Air equipment has standard air leakage within certain limits.
- Do not use this equipment when the air itself can lead to explosion danger.

**CAUTION**

- Do not install and use this equipment in case of vibration such to lead to equipment failure. Contact SMC for this specific situation.

**WARNING**

- External impact on the rotary actuator body could result in spark and/or rotary actuator damage. Avoid any application where foreign objects can hit the rotary actuator. In such situations install suitable guard to prevent such impacts.
- Use only ATEX certified auto-switch. Order them separately.
- Do not use in presence of strong magnetic fields, which could generate surface temperature higher than the value given for the temperature class.

**6 EUROPEAN CONTACT LIST**

**SMC Corporation**

Country	Telephone	Country	Telephone
Austria	(43) 2262-62 280	Italy	(39) 02-92711
Belgium	(32) 3-355 1464	Netherlands	(31) 20-531 8888
Czech Republic	(420) 5-414 24611	Norway	(47) 67 12 90 20
Denmark	(45) 70 25 29 00	Poland	(48) 22-548 50 85
Finland	(358) 9-859 580	Portugal	(351) 22 610 89 22
France	(33) 1-64 76 1000	Spain	(34) 945-18 4100
Germany	(49) 6103 4020	Sweden	(46) 8-603 0700
Greece	(30) 1- 342 6076	Switzerland	(41) 52-396 3131
Hungary	(36) 1-371 1343	Turkey	(90) 212 221 1512
Ireland	(353) 1-403 9000	United Kingdom	(44) 1908-56 3888

**Websites**

SMC Corporation [www.smcworld.com](http://www.smcworld.com)  
 SMC Europe [www.smceu.com](http://www.smceu.com)