



Installation and Maintenance Manual

52-SY5000 Series Intrinsically Safe Solenoid Valve

Applicable Manifold Types: 41, 42 and 20



Read this manual before using this product

- For future reference, please keep manual in a safe place.
- The information within this document is to be used by pneumatically trained personnel only.
- This manual should be read in conjunction with the current catalogue.

Marking description	
II 2G EEx ia IIB T4,T5 Max. Tamb. =50°C	
II 2G EEx ia IIB T6 Max. Tamb. =45°C	
Group II Category 2 Suitable for Gas environment KEMA 02ATEX1099X	

1 SAFETY

1.1 General recommendation

These safety instructions are intended to prevent a hazardous situation and/or equipment damage. These instructions indicate the level of potential hazard by label of "Caution", "Warning" or "Danger". To ensure safety, be sure to observe ISO4414 (Note1), JIS B 8370 (Note2) and other safety practices.

Note 1:ISO 4414:Pneumatic fluid power - Recommendations for the application of equipment to transmission and control systems. Note 2:JIS B 8370:Pneumatic system axiom.

CAUTION: Operator error could result in injury or equipment damage.

WARNING: Operator error could result in serious injury or loss of life.

DANGER: In extreme conditions, there is a possible result of serious injury or loss of life.

WARNING

- The compatibility of pneumatic equipment is the responsibility of the person who designs the pneumatic system or decides its specifications.
 - Since the products specified here are used in various operating conditions, their compatibility for the specific pneumatic system must be based on specifications or after analysis and/or tests to meet your specific requirements.
- Only trained personnel should operate pneumatically operated machinery and equipment.
 - Compressed air can be dangerous if an operator is unfamiliar with it Assembly, handling or repair of pneumatic systems should be performed by trained and experienced operators.
- Do not service machinery/equipment or attempt to remove component until safety is confirmed.
 - Inspection and maintenance of machinery/equipment should only be performed after confirmation of safe locked-out control positions.
 - When equipment is to be removed, confirm the safety process as mentioned above. Switch off air and electrical supplies and exhaust all residual compressed air in the system.
 - Before machinery/equipment is re-started, ensure all safety measures to prevent sudden movement of cylinders etc. (Bleed air into the system gradually to create backpressure, i.e. incorporate a soft-start valve).
- Contact SMC if the product is to be used in any of the following conditions:
 - Conditions and environments beyond the given specifications, or if product is used outdoors.
 - Installations in conjunction with atomic energy, railway, air navigation, vehicles, medical equipment, food and beverage, recreation equipment, emergency stop circuits, press applications, or safety equipment.
 - An application, which has the possibility of having negative effects on people, property, or animals, requiring special safety analysis.

- CAUTION:**
- Ensure that the air supply system is filtered to 5 micron

1.2 Conformity to standard

This product is certified to and complies with the following standards:

Directive	Standard
EMC	EN 55022 EN 61000-6-2
Equipment or protective system intended for use in potentially explosive atmospheres	EN 50014 EN 50020 EN 50284 EN 13463-1

1.3 Specific recommendations

WARNING

- This product enclosure is made of Aluminium alloy. When mounting this product, it must be installed such, that, even in the event of rare incidents, ignition sources due to impact and friction sparks are excluded.
- The valves within the scope of this document must not be used with plastic manifolds.
- Not suitable for Zone 0 applications. Only Suitable for Zone 1 and 2.

2 INTENDED CONDITIONS OF USE

2.1 Specifications

Fluid	Air	
Operating pressure range (MPa)	Single	0.15 ~ 0.7
	Double	0.1 ~ 0.7
	3 pos.	0.2 ~ 0.7
Ambient and fluid temperature (°C) (No Freezing)	For temperature class T6	Max. 45
	For temperature class T4, T5	Max. 50
Maximum operating frequency (Hz)	Two position	5
	Three position	3
Lubrication	Not required	
Mounting position	Free	
Impact/vibration resistance (m/s ²) (note1)	150/30	
Enclosure protection	Connector without cover	IP30
	Terminal block	IP65

Note1:

- Impact resistance: There should be no malfunction of the valve after testing using a drop impact tester along the valve axis and at right angles to the valve and armature. Carry out each test with the valve energised and de-energised (Value at initial stage).
- Vibration resistance: There should be no malfunction of the valve after testing using an 8.3 to 2000Hz sweep along the valve axis and at right angles to the valve and armature. Carry out each test with the valve energised and de-energised (Value at initial stage).

Solenoid

Coil insulation type	B (130°C)
Input voltage (hazardous area) (V)	12DC
Input voltage tolerance	±10%
Power consumption (W)	0.52
Ignition protection	II 2G EEx ia IIB T4,T5 Max. Tamb. =50°C II 2G EEx ia IIB T6 Max. Tamb. =45°C
Certificate of conformity	KEMA 02ATEX1099X
Equipment category	II 2G
Production date	Refer to table below and product label

Construction Month	Jan	Feb	Mar	Apr	May	Jun	Jul	Aug	Sep	Oct	Nov	Dec
2004	IO	IP	IQ	IR	IS	IT	IU	IV	IW	IX	IY	IZ
2005	JO	JP	JQ	JR	JS	JT	JU	JV	JW	JX	JY	JZ
2006	KO	KP	KQ	KR	KS	KT	KU	KV	KW	KX	KY	KZ

2.2 Piping

Use antistatic tubing if required by the application.
For port identification, see section 3.2.

2.3 Circuit Symbols

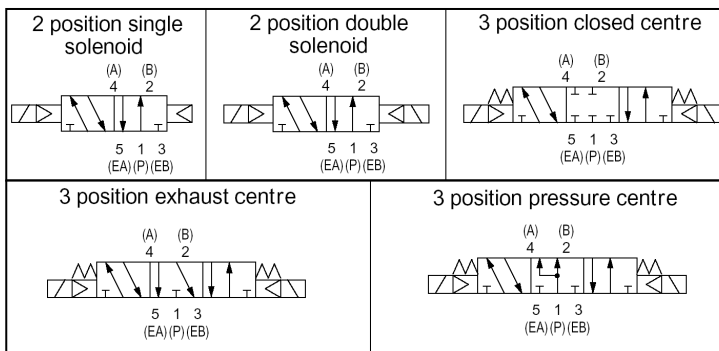

3 INSTALLATION

WARNING

- Do not install unless the safety instructions have been read and understood.

3.1 Environment

WARNING

- Do not use in an environment where the product is directly exposed to corrosive gases, chemicals, salt water, water or steam.
- The product should not be exposed to prolonged sunlight. Use a protective cover.
- Do not mount the product in a location where it is subject to strong vibrations and/or shock. Check the product specifications for above ratings.
- Do not mount the product in a location where it is exposed to radiant heat.

3.2 Piping

CAUTION

- Before piping make sure to clean up chips, cutting oil, dust etc.
- When installing piping or fitting into a port, ensure that sealant material does not enter the port inside. When using seal tape, leave 1.5 to 2 threads exposed on the end of pipe/fitting.

Port Size	Appropriate tightening torque (Nm)
M5	By hand + 1/6 turn with the wrench (1/4 turn for miniature fittings)
1/8	7 to 9
1/4	12 to 14

20 Type valve (body ported)

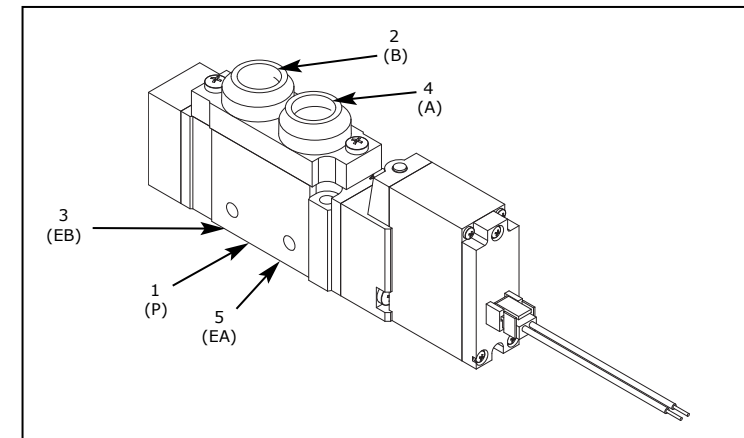

40 Type valve (base mounted)

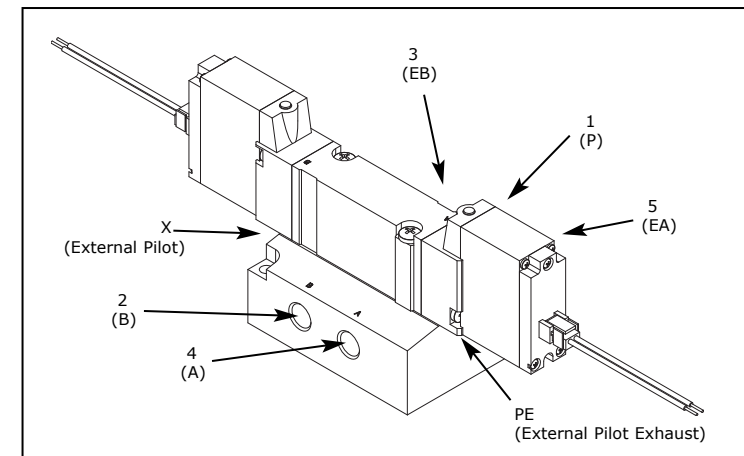

3.3 Electrical connection

CAUTION

- When DC power is connected to a solenoid valve equipped with light and/or surge voltage suppressor, check for polarity indications.
- For polarity indications:
 - No diode to protect polarity: if polarity connection is wrong, the diode in the valve or switching device at control equipment or power supply may be damaged.
 - With diode to protect polarity: if polarity connection is wrong, the valve does not switch.

Terminal block type

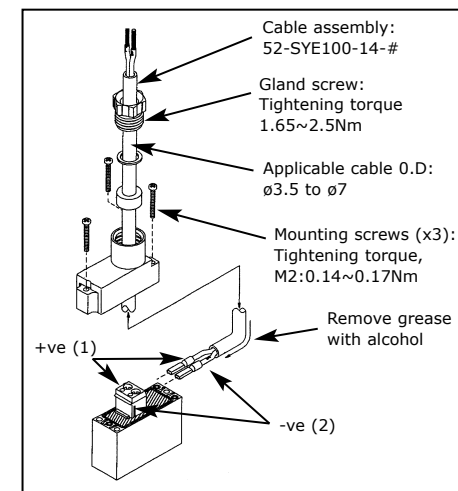

Plug connector type

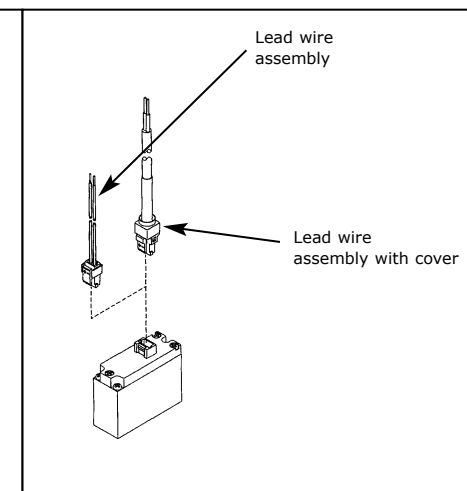

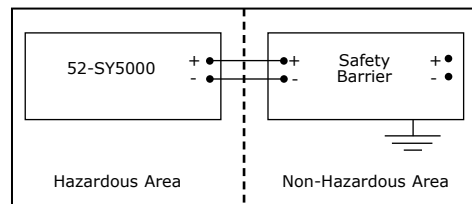

Reversing of electrical polarity can damage the safety barrier.
 The product should be connected to a certified, intrinsically safe circuit with the following maximum values:

$U_i = 28V$
 $I_i = 225mA$ (resistively limited)
 $P_i = 1W$
 $C_i = 0nF$
 $L_i = 0mH$

3.4 Mounting

20 Type Manifold

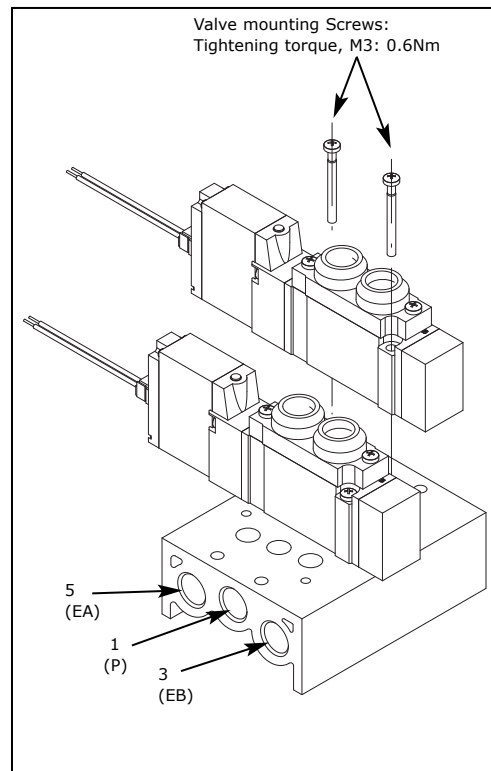

41 and 42 Type Manifold

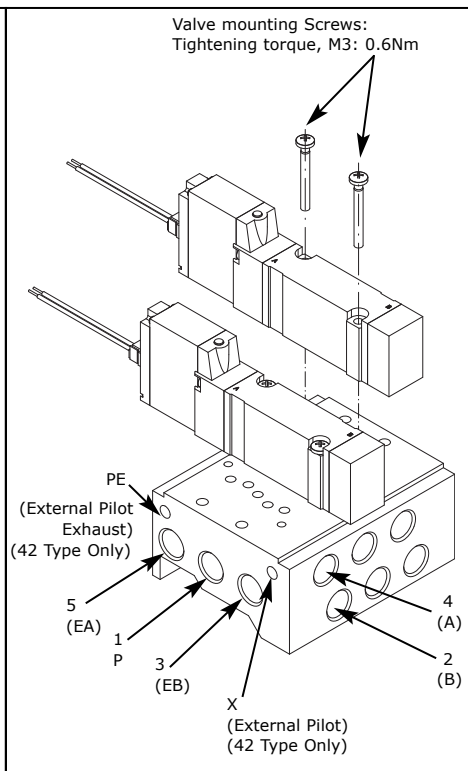

3.5 Lubrication

CAUTION:

- SMC products have been lubricated for life at manufacturer, and do not require lubrication in service.
- If a lubricant is used in the system, use turbine oil Class 1(no additive), ISO VG32. Once lubricant is used in the system, lubrication must be continued because the original lubricant applied during manufacturing will be washed away.

4. SETTINGS AND PROGRAMMING

Manual Override Types

Non-locking push style
Press in the direction of the arrow.

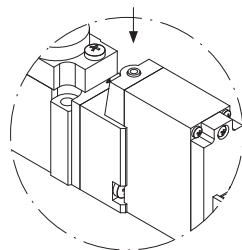

Push-turn locking style
Press in the direction of the arrow.
Turn to lock. Max torque: 0.1Nm

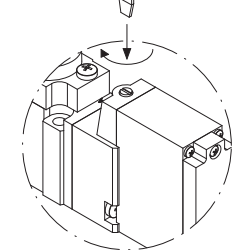

Push-turn locking lever style
Press in the direction of the arrow.
Turn to lock.

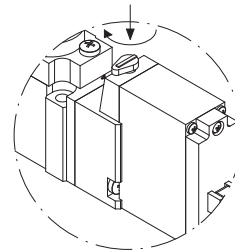

5. MAINTENANCE

WARNING:

- Not following proper procedures could cause the product to malfunction and could lead to damage to the equipment or machine.
- If handled improperly, compressed air can be dangerous. Assembly, handling and repair of pneumatic system should be performed by qualified personnel only.
- Drain: remove condensate from the filter bowl on a regular basis.
- Shut-down before maintenance: before attempting any kind of maintenance make sure the supply pressure is shut off and all residual air pressure is released from the system to be worked on.
- Start-up after maintenance: apply operating pressure and power to the equipment and check for proper operation and possible air leaks. If operation is abnormal, please verify product set-up parameters.
- Do not make any modification to the product.
- Do not disassemble the product, unless required by installation or maintenance instructions.

Changing pilot valves

Disconnect power supply before changing pilot valve.

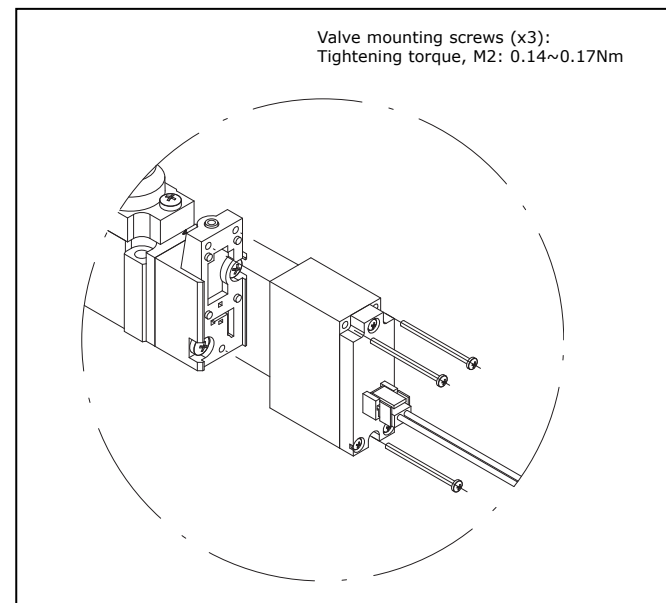

Valve mounting brackets

For all other spares, see 52- SY catalogue.

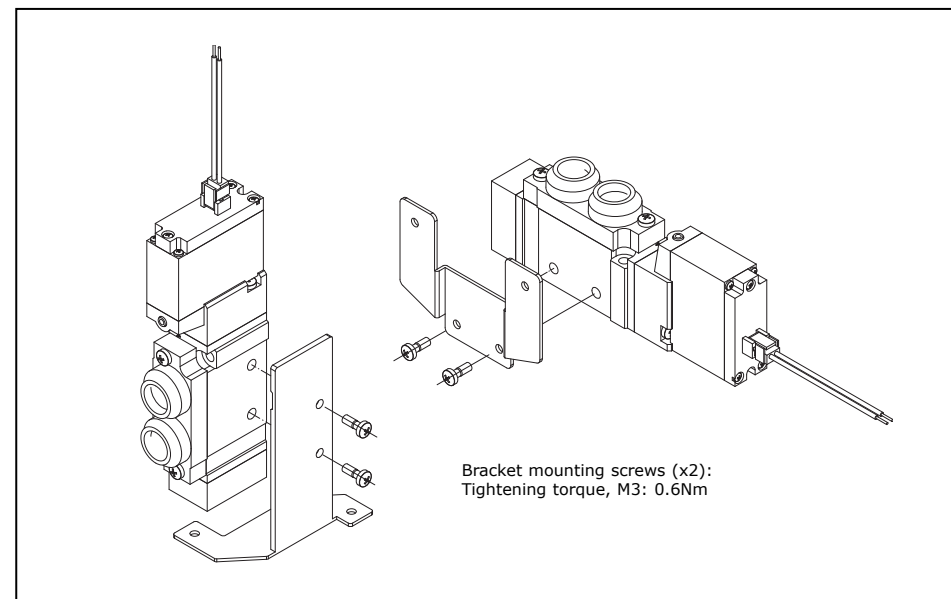

6. LIMITATIONS OF USE

WARNING:

- Do not exceed any of the specifications laid out in section 2 of this document or the specific product catalogue.
- Also refer to sections 1.3 and 2.2 for additional, product specific information.

7 EUROPEAN CONTACT LIST

7.1 SMC Corporation

ENGLAND	01908-563888	GREECE	01-3426076	SWEDEN	08-6030700
ITALY	02-92711	FINLAND	09-68 10 21	AUSTRIA	02262-62-28
HOLLAND	020-5318888	BELGIUM	03-3551464	IRELAND	01-4501822
SWITZERLAND	052-34-0022	TURKEY	212-2211512	DENMARK	87 38 87 00
SPAIN	945-184100	GERMANY	6103-402-0	NORWAY	67 12 90 20
	902-255255	FRANCE	01-64761000	POLAND	48-22-6131847

7.2 Websites

SMC Corporation www.smcworld.com SMC Europe www.smceu.com