



Installation and Maintenance Manual

Auto Switch (Solid State)

Series D-F6N#-588

Series D-F6P#-588

Series D-F6B#-588

CE Ex II 3GD EEx nA II T5 X -10°C ≤ Ta ≤ +60°C IP67

Read this manual before using this product.

- For future reference, please keep this manual in a safe place.
- This manual should be read in conjunction with the current catalogue.

ATEX marking description

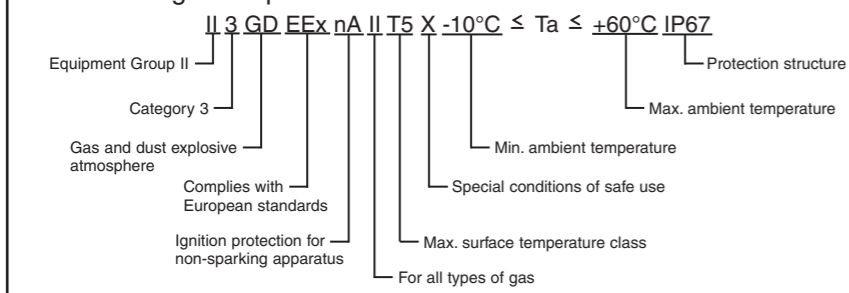

1 SAFETY

1.1 General recommendation

These safety instructions are intended to prevent a hazardous situation and/or equipment damage. These instructions indicate the level of potential hazard by label of "Caution", "Warning" or "Danger". To ensure safety, be sure to observe ISO4414 (Note1), JIS B 8370 (Note2) and other safety practices.

(Note 1) : ISO 4414 : Pneumatic fluid power - Recommendations for the application of equipment to transmission and control systems.
(Note 2) : JIS B 8370 : Pneumatic system axiom.



CAUTION : Operator error could result in injury or equipment damage.



WARNING : Operator error could result in serious injury or loss of life.



DANGER : In extreme conditions, there is a possible result of serious injury or loss of life.



WARNING

- The compatibility of pneumatic equipment is the responsibility of the person who designs the pneumatic system or decides its specifications.
 - Since the products specified here are used in various operating conditions, their compatibility for the specific pneumatic system must be based on specifications or after analysis and/or tests to meet your specific requirements.
- Only trained personnel should operate pneumatically operated machinery and equipment.
 - Compressed air can be dangerous if an operator is unfamiliar with it. Assembly, handling or repair of pneumatic systems should be performed by trained and experienced operators.
- Do not service machinery/equipment or attempt to remove component until safety is confirmed.
 - Inspection and maintenance of machinery/equipment should only be performed after confirmation of safe locked-out control positions.
 - When equipment is to be removed, confirm the safety process as mentioned above. Switch off air and electrical supplies and exhaust all residual compressed air in the system.
 - Before machinery/equipment is re-started, ensure all safety measures to prevent sudden movement of actuators etc. (Supply air into the system gradually to create backpressure, i.e. incorporate a soft-start valve).
- Contact SMC if the product is to be used in any of the following conditions:
 - Conditions and environments beyond the given specifications, or if product is used outdoors.
 - Installations in conjunction with atomic energy, railway, air navigation, vehicles, medical equipment, food and beverage, recreation equipment, emergency stop circuits, press applications, or safety equipment.
 - Applications which have the possibility of having negative effects on people, property or animals. Special safety analysis is required.

1.2 Conformity to standard

This product is certified to and complies with the following standards:

ATEX Directive 94/9/EC

- EN 50021 : 1999 Electrical apparatus for potentially explosive atmospheres - Type of protection "n"
- EN 50281-1-1 : 1999 Electrical apparatus protected by enclosures - construction and testing.

EMC Directive 89/336/EEC

- EN61000-6-2 : 2001 Electromagnetic compatibility (EMC). Generic standards. Immunity standard for industrial environments.

2 INSTALLATION AND OPERATING ENVIRONMENT



WARNING

Design and selection

- Confirm the specifications.
Read the specifications carefully and use this product appropriately. The product may be damaged or malfunction if it is used outside the range of specifications for load current, voltage, temperature or impact.
- Take precautions when multiple actuators are used close together.
When multiple auto switch actuators are used in close proximity, magnetic field interference may cause the switches to malfunction. Maintain a minimum actuator separation of 40mm.
- Pay attention to the length of time that a switch is ON at an intermediate stroke position.
When an auto switch is placed at an intermediate position of the stroke and a load is driven at the time the piston passes, the auto switch will operate, but if the speed is too great the operating time will be shortened and the load may not operate properly. The maximum detectable piston speed is :

$$V[\text{mm/s}] = \frac{\text{Autoswitch operating range [mm]}}{\text{Load operating time [ms]}} \times 1000$$

- Keep wiring as short as possible.
Although longer wiring does not affect the function, please keep it to 100m or shorter.
- Do not use a load that generates surge voltage.
Although a zener diode for surge protection is connected at the output side of a solid state auto switch, damage may still occur if the surge is applied repeatedly. When a load such as a relay or solenoid which generates surge is directly driven, use a type of switch with a built-in surge absorbing element.
- Cautions for use in an interlock circuit
When an auto switch is used for an interlock signal requiring high reliability, devise a double interlock system to avoid trouble by providing a mechanical protection function, or by also using another switch (sensor) together with the auto switch. Also perform periodic maintenance and confirm proper operation.
- Ensure sufficient clearance for maintenance activities.
When designing an application, be sure to allow sufficient clearance for maintenance and inspections.

Mount / adjustment

- Do not drop or bump.
Do not drop, bump or apply excessive impacts (1000m/s² or more for solid state switches) while handling. Although the body of the switch may not be damaged, the inside of the switch could be damaged and cause a malfunction.
- Do not carry a actuator by the auto switch lead wires.
Never carry a actuator by its lead wires. This may not only cause broken lead wires, but it may cause internal elements of the switch to be damaged by the stress.
- Mount switches using the proper tightening torque.
If a switch is tightened beyond the range of tightening torque, the mounting screws, mounting brackets or switch may be damaged. On the other hand, tightening below the range of tightening torque may allow the switch to slip out of position.



WARNING

- Mount a switch at the center of the operating range.
Adjust the mounting position of an auto switch so that the piston stops at the center of the operating range (the range in which a switch is ON). (The mounting position shown in the catalog indicates the optimum position at stroke end.) If mounted at the end of the operating range (around the borderline of ON and OFF), operation may be unstable.

Wiring

- Avoid repeatedly bending or stretching lead wires.
Broken lead wires can result from wiring patterns which repeatedly apply bending stress or stretching force to the lead wires.
- Confirm proper insulation of wiring.
Be certain that there is no faulty wiring insulation (contact with other circuits, ground fault, improper insulation between terminals, etc.) Damage may occur due to excess current flow into a switch.
- Do not wire with power lines or high voltage lines.
Wire separately from power lines or high voltage lines, avoiding parallel wiring or wiring in the same conduit with these lines. Control circuits containing auto switches may malfunction due to noise from these other lines.
- Do not allow short circuit of loads.
All models of PNP output type switches do not have built-in short circuit protection circuits. Note that if a load is short circuited, the switch will be internally damaged because of excess current flow into the switch.
- Avoid incorrect wiring.
If incorrect wiring, the switches will be damaged.
- When stripping the cable envelope, please pay attention to the stripping direction.
Insulator might be split or hurt depending on the directions.



Operating environment

- Do not use in an area where a magnetic field is generated.
Auto switches can malfunction or magnets inside actuators can become demagnetized.
- Do not use in an environment where the auto switch will be continually exposed to water.
Although switches satisfy IEC standard IP67 construction (JIS C 0920: watertight construction), avoid using switches in applications where continually exposed to water splash or spray. Poor insulation or swelling of the potting resin inside switches may cause malfunction.
- Do not use in an environment with oil or chemicals.
Consult SMC if auto switches will be used in an environment with coolant, cleaning solvent, various oils or chemicals. If auto switches are used under these conditions for even a short time, they may be adversely affected by improper insulation, malfunction due to swelling of the potting resin, or hardening of the lead wires.
- Do not use in an environment with temperature cycles.
Consult SMC if switches are used where there are temperature cycles other than normal air temperature changes, as there may be adverse effects inside the switches.
- Do not use in an area where surges are generated.
When there are units (solenoid type lifter, high frequency induction furnace, motor, etc.) which generate a large amount of surge in the area around actuators with solid state auto switches, this may cause deterioration or damage to the switches. Avoid sources of surge generation and crossed lines.
- Avoid accumulation of iron waste or close contact with magnetic substances.
When a large amount of iron waste such as machining chips or spatter is accumulated, or a magnetic substance (something attracted by a magnet) is brought into close proximity with an auto switch actuator, it may cause auto switches to malfunction due to a loss of the magnetic force inside the actuator.

2 INSTALLATION AND OPERATING ENVIRONMENT (continued)

Maintenance

- Perform the following maintenance periodically in order to prevent possible danger due to unexpected auto switch malfunction.
 - Securely tighten switch mounting screws.
If screws become loose or the mounting position is dislocated, retighten them after readjusting the mounting position.
 - Confirm that there is no damage to lead wires.
To prevent faulty insulation, replace switches or repair lead wires, etc., if damage is discovered.

Others

- For durability against water, elasticity, application at welding site, please consult us.
- If ON and OFF position (hysteresis) cause problems, please consult us.

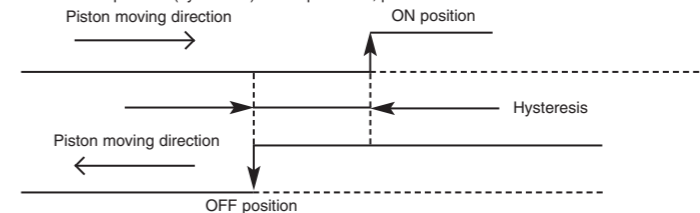

3 MODEL INDICATION METHOD

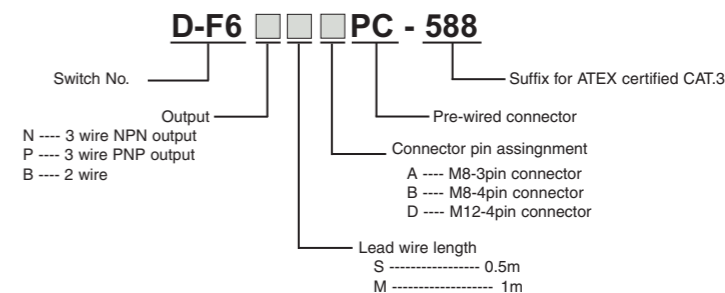
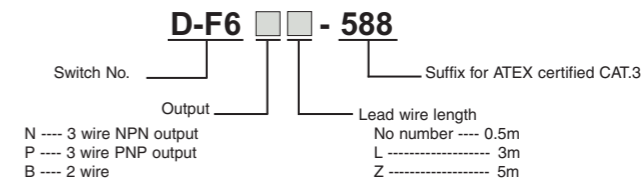

This product is a Solid State Auto Switch of direct mounting specification. Switch should only be used in areas in which potentially explosive atmospheres are unlikely to be present or only present for short periods of time.

4 INTENDED CONDITIONS OF USE

The auto switch should be used within the range of specifications below and the auto switch catalogue. If labelled with X : special conditions applied: Protect the auto switch against all impact or mechanical damage. The switch should not be exposed to prolonged sunlight that can generate surface temperature higher than the value given for temperature class. Use a protective cover. If foreign particles (E.g. iron dust, weld spatter) are allowed to accumulate around the switch, it could reduce the magnetic field strength, and may effect the detection signal. Clean away these particles.

Switch model number	D-F6N	D-F6P	D-F6B
Wiring	3 wire		2 wire
Output	NPN	PNP	-
Application	IC circuit/Relay/PLC		24VDC Relay/PLC
Power voltage	5/12/24VDC (4.5 to 28VDC)		-
Current consumption	10mA or less		-
Load voltage	28VDC or less	-	24VDC (10 to 28VDC)
Load current	40mA or less		2.5 to 40mA
Internal voltage drop	0.8V or less		4V or less
Current leakage	100µA or less at 24VDC		0.8mA or less
Operating time	1ms or less		
Indication light	ON : Red light emitting diode		
Electrical entry system	Grommet		
Lead wire	Oilproof heavy-duty vinyl cord 2.7×3.2 oval, 0.15mm ² , 2 wire (D-F6B), 3 wire (D-F6N, D-F6P)		
Impact resistance	1000m/s ²		
Insulation resistance	50MΩ or more at 500VDC mega		
Withstand voltage	1000VAC for 1 minute (lead wire, between cases)		
Ambient temperature	-10 to 60 °C		
Protection structure	IEC60529 standard IP67, JIS C0920		

5 NAMES AND FUNCTIONS OF INDIVIDUAL PARTS

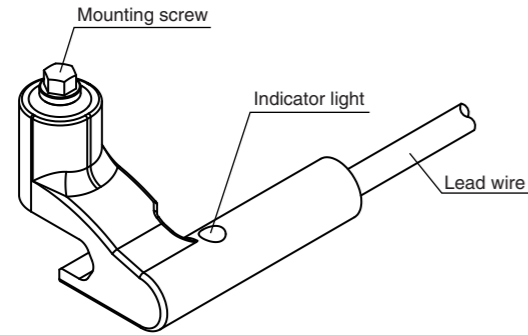

6 HOW TO MOUNT / MOUNTING BRACKET

When mounting an auto switch on an actuator it should be done with the actuator clamp. "How to mount" depends on actuator type and tube I.D. Please refer the actuator catalogue. When an auto switch is mounted for the first time, please ensure the actuator is of the magnet built in type, then prepare the corresponding brackets for the actuator.

- Proper tightening torque
Use special tool or torque wrench for tightening the set screw.
M3 mount screw tightening torque shall be 0.8 to 1.4N•m.

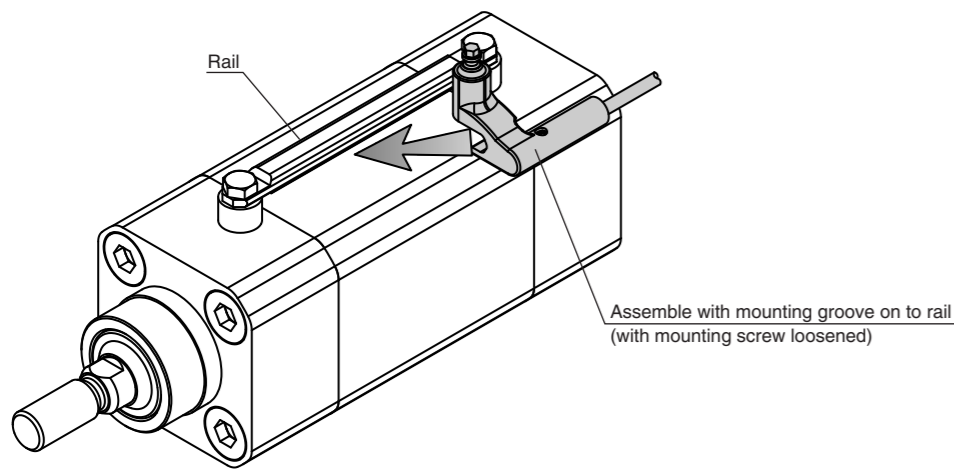

Tighten the mounting screw when in required position

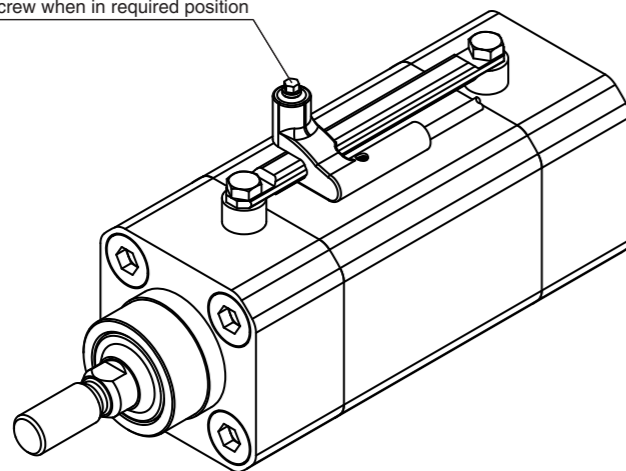

- Setting the detecting position
Set the actuator at the stroke end. Set the switch in the area to where the auto switch red lamp lights. (Detecting actuator end)
Based on A and B dimensions in the actuator catalogue, set the switch.

7 BASIC WIRING

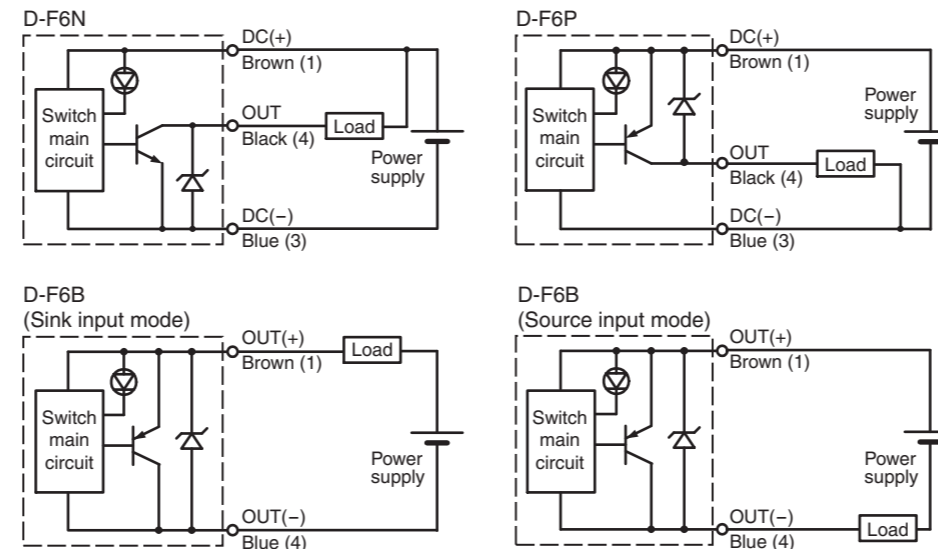

Connector Pin Assignment

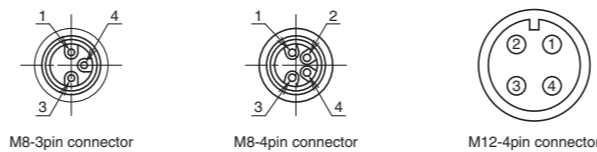

8 EXTERIOR DIMENSION

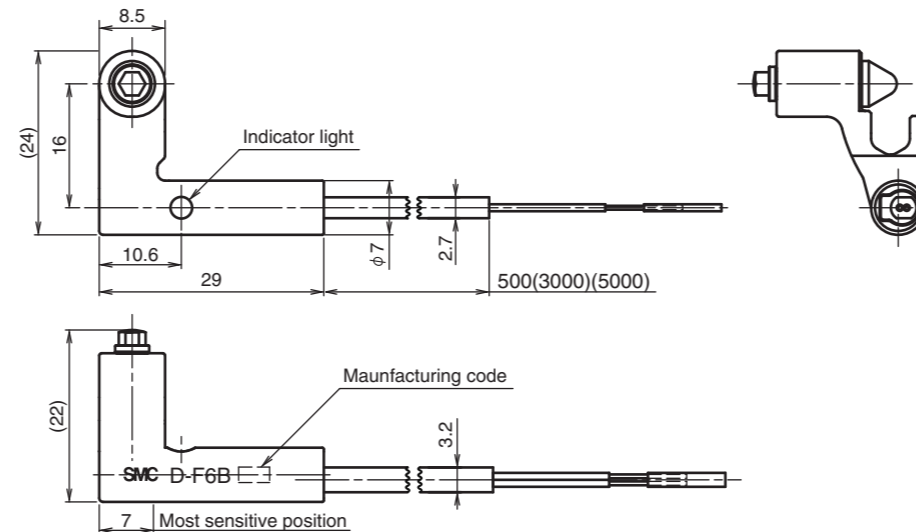

Manufacturing code

Year		Month	
Mark	Year	Mark	Month
L	2007	o	January
M	2008	P	February
N	2009	Q	March
o	2010	R	April
P	2011	S	May
Q	2012	T	June
⋮	⋮	U	July
		V	August
		W	September
		X	October
		y	November
		Z	December

9 CHECK FLOW

When detection failure occurs (stays ON/OFF), please check based on the following flow chart.

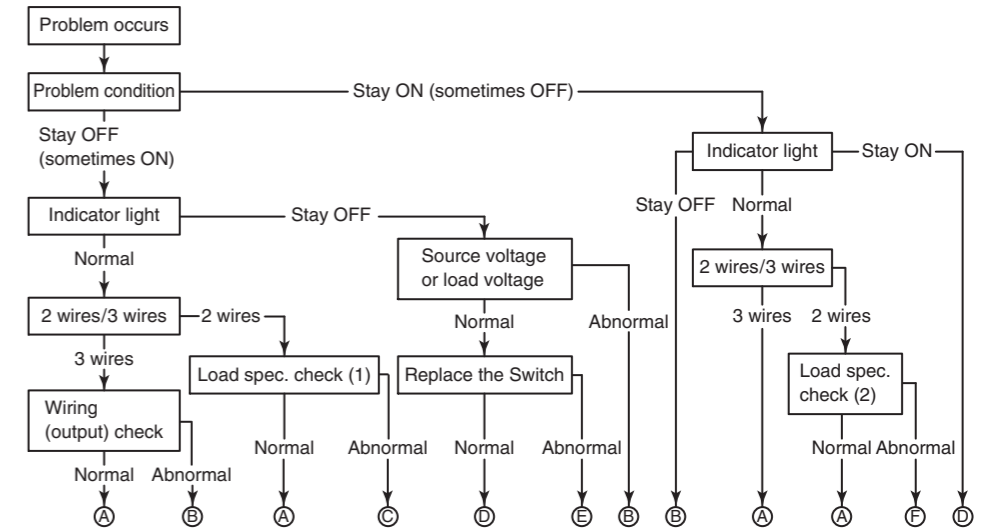

Load spec. check (1) --- ON voltage > Load voltage-Internal voltage drop
Load spec. check (2) --- OFF current > Leak current

- (A) --- Switch output parts failure (replace)
- (B) --- Check wiring and correct fault
- (C) --- Replace switch 2 wires --> 3 wires
- (D) --- Switch failure
- (E) --- Replace cylinder. Detectable magnet field inadequate (No magnet)
- (F) --- Replace PLC input board or replace switch 2 wires --> 3 wires

Exterior dimension of Pre-wired connector

D-F6□□PC-588

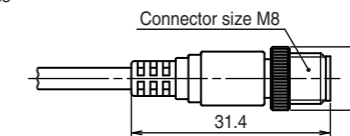

D-F6□□DPC-588

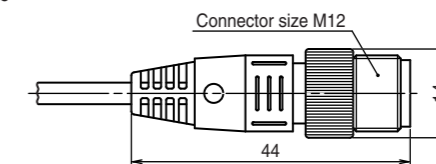

<NOTES>

When you inquire about the product, please contact the following:

SMC Corporation

Country	Telephone	Country	Telephone
AUSTRIA	(43) 2262 62280	NETHERLANDS	(31) 20 531 8888
BELGIUM	(32) 3 355 1464	NORWAY	(47) 67 12 90 20
CZECH REP.	(420) 541 424 611	POLAND	(48) 22 211 9600
DENMARK	(45) 7025 2900	PORTUGAL	(351) 21 471 1880
FINLAND	(358) 207 513513	SLOVAKIA	(421) 2 444 56725
FRANCE	(33) 1 6476 1000	SLOVENIA	(386) 73 885 412
GERMANY	(49) 6103 4020	SPAIN	(34) 945 184 100
GREECE	(30) 210 271 7265	SWEDEN	(46) 8 603 1200
HUNGARY	(36) 23 511 390	SWITZERLAND	(41) 52 396 3131
IRELAND	(353) 1 403 9000	UNITED KINGDOM	(44) 1908 563888
ITALY	(39) 02 92711		

Websites

SMC Corporation www.smcworld.com
SMC Europe www.smceu.com