



Installation & Maintenance Manual

Auto Switch (Solid State)

Series D-F7NJL



EMC Directives
EN61000-6-2:2001 Electromagnetic Compatibility (EMC). Generic standards - Immunity for industrial environments.
EN55011 A1+A2:2001 Limits and methods of measurement of radio disturbance characteristics of industrial, scientific and medical radio-frequency equipment and light industrial environments.

Read this manual before using this product.
For future reference, please keep this manual in a safe place.
This manual should be read in conjunction with the current catalogue.

1.1 General recommendation

These safety instructions are intended to prevent a hazardous situation and/or equipment damage.
These instructions indicate the level of potential hazard by label of "Caution", "Warning" or "Danger".
To ensure safety, be sure to observe ISO4414 (Note1), JIS B 8370 (Note2) and other safety practices.

Caution : Operator error could result in injury or equipment damage.

Warning : Operator error could result in serious injury or loss of life.

Danger : In extreme conditions, there is a possible result of serious injury or loss of life.

(Note 1):ISO 4414:Pneumatic fluid power - Recommendations for the application of equipment to transmission and control systems.

(Note 2):JIS B 8370:Pneumatic system axiom.

Warning

1.1.1.The compatibility of pneumatic equipment is the responsibility of the person who designs the pneumatic system or decides its specifications.

Since the products specified here are used in various operating conditions,their compatibility for the specific pneumatic system must be based on specifications or after analysis and/or tests to meet your specific requirements.

1.1.2.Only trained personnel should operate pneumatically operated machinery and equipment.

Compressed air can be dangerous if an operator is unfamiliar with it Assembly, handling or repair of pneumatic systems should be performed by trained and experienced operators.

1.1.3.Do not service machinery/equipment or attempt to remove component until safety is confirmed.

1) Inspection and maintenance of machinery/equipment should only be performed after confirmation of safe locked-out control positions.

2) When equipment is to be removed, confirm the safety process as mentioned above. Switch off air and electrical supplies and exhaust all residual compressed air in the system.

3) Before machinery/equipment is re-started, ensure all safety measures to prevent sudden movement of actuators etc. (Supply air into the system gradually to create backpressure, i.e. incorporate a soft-start valve).

1.1.4.Contact SMC if the product is to be used in any of the following conditions:

1) Conditions and environments beyond the given specifications, or if product is used outdoors.

2) Installations in conjunction with atomic energy, railway, air navigation, vehicles, medical equipment, food and beverage, recreation equipment, emergency stop circuits, press applications, or safety equipment.

3) Equipment intended for use in potentially explosive atmospheres. Applications which have the possibility of having negative effects on people, property or animals. Special safety analysis is required.

2. INSTALLATION AND OPERATING ENVIRONMENT

Warning

Design and selection

① Confirm the specifications.

Read the specifications carefully and use this product appropriately. The product may be damaged or malfunction if it is used outside the range of specifications for load current, voltage, temperature or impact.

② Take precautions when multiple actuators are used close together. When multiple auto switch actuators are used in close proximity, magnetic field interference may cause the switches to malfunction. Maintain a minimum actuator separation of 40mm.

③ Pay attention to the length of time that a switch is ON at an intermediate stroke position.

When an auto switch is placed at an intermediate position of the stroke and a load is driven at the time the piston passes, the auto switch will operate, but if the speed is too great the operating time will be shortened and the load may not operate properly. The maximum detectable piston speed is:

$$V_{[mm/s]} = \frac{\text{Autoswitch operating range [mm]}}{\text{Load operating time [ms]}} \times 1000$$

④ Keep wiring as short as possible

Although longer wiring does not affect the function, please keep it to 100m or shorter.

⑤ Do not use a load that generates surge voltage.

Although a zener diode for surge protection is connected at the output side of a solid state auto switch, damage may still occur if the surge is applied repeatedly. When a load such as a relay or solenoid which generates surge is directly driven, use a type of switch with a built-in surge absorbing element.

⑥ Cautions for use in an interlock circuit

When an auto switch is used for an interlock signal requiring high reliability, devise a double interlock system to avoid trouble by providing a mechanical protection function, or by also using another switch (sensor) together with the auto switch.

Also perform periodic maintenance and confirm proper operation.

⑦ Ensure sufficient clearance for maintenance activities.

When designing an application, be sure to allow sufficient clearance for maintenance and inspections.

Mount / adjustment

① Do not drop or bump.

Do not drop, bump or apply excessive impacts (1000m/s² or more for solid state switches) while handling. Although the body of the switch may not be damaged, the inside of the switch could be damaged and cause a malfunction.

② Do not carry a actuator by the auto switch lead wires.

Never carry an actuator by its lead wires. This may not only cause broken lead wires, but it may cause internal elements of the switch to be damaged by the stress.

③ Mount switches using the proper tightening torque.

If a switch is tightened beyond the range of tightening torque, the mounting screws, mounting brackets or switch may be damaged. On the other hand, tightening below the range of tightening torque may allow the switch to slip out of position.

④ Mount a switch at the center of the operating range.

Adjust the mounting position of an auto switch so that the piston stops at the center of the operating range (the range in which a switch is ON). (The mounting position shown in the catalog indicates the optimum position at stroke end.) If mounted at the end of the operating range (around the borderline of ON and OFF), operation may be unstable.

Wiring

① Avoid repeatedly bending or stretching lead wires.

Broken lead wires can result from wiring patterns which repeatedly apply broken stress or stretching force to the lead wires.

② Confirm proper insulation of wiring.

Be certain that there is no faulty wiring insulation (contact with other circuits, ground fault, improper insulation between terminals, etc.) Damage may occur due to excess current flow into a switch.

③ Do not wire with power lines or high voltage lines.

Wire separately from power lines or high voltage lines, avoiding parallel wiring or wiring in the same conduit with these lines. Control circuits containing auto switches may malfunction due to noise from these other lines.

④ Do not allow short circuit of loads.

All models of PNP output type switches do not have built-in short circuit protection circuits.

Note that if a load is short circuited, the switch will be instantly damaged because of excess current flow into the switch.

*Take special care to avoid reverse wiring of the brown power supply line and the black output line on 3-wire type switches.

Warning

⑤ Avoid incorrect wiring

If connections are reversed (power supply line + and power supply line -) on a 3-wire type switch, the switch will be protected by a protection circuit. However, if the power supply line (+) is connected to the blue wire and the power supply line (-) is connected to the black wire, the switch will be damaged.

⑥ Do not cut lead wire between sensor and amplifier part.

Circuit of sensor and amplifier are adjusted integrally, if sensor part is replaced, switch can not operate properly.

Operating environment

① Do not use in an area where a magnetic field is generated.

Auto switches can malfunction or magnets inside actuators can become demagnetized.

② Do not use in an environment where the auto switch will be continually exposed to water.

Although switches satisfy IEC standard IP67 construction (JIS C 0920: watertight construction), avoid using switches in applications with continual exposure to water splash or spray. Poor insulation or swelling of the potting resin inside switches may cause malfunction.

③ Do not use in an environment with oil or chemicals.

Consult SMC if auto switches are to be used in an environment with coolant, cleaning solvent, various oils or chemicals. If auto switches are used under these conditions for even a short time, they may be adversely affected by improper insulation, malfunction due to swelling of the potting resin, or hardening of the lead wires.

④ Do not use in an environment with temperature cycles.

Consult SMC if switches are used where there are temperature cycles other than normal air temperature changes, as there may be adverse effects inside the switches.

⑤ Do not use in an area where surges are generated.

When there are units (solenoid type lifter, high frequency induction furnace, motor, etc.) which generate a large amount of surge in the area around actuators with solid state auto switches, this may cause deterioration or damage to the switches. Avoid sources of surge generation and crossed lines.

⑥ Avoid accumulation of iron waste or close contact with magnetic substances.

When a large amount of iron waste such as machining chips or spatter has accumulated, or a magnetic substance (something attracted by a magnet) is brought into close proximity with an auto switch actuator, it may cause auto switches to malfunction due to a loss of the magnetic force inside the actuator.

Maintenance

① Perform the following maintenance periodically in order to prevent possible danger due to unexpected auto switch malfunction.

1) Securely tighten switch mounting screws.

If screws become loose or the mounting position is dislocated, retighten them after readjusting the mounting position.

2) Confirm that there is no damage to lead wires.

To prevent faulty insulation, replace switches or repair lead wires, etc., if damage is discovered.

Others

① For durability against water, elasticity, application at welding site, please consult us.

② If ON and OFF position (hysteresis) cause problems, please consult us.

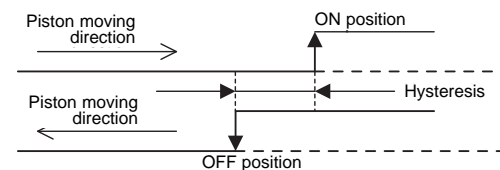

3.Model Indication Method

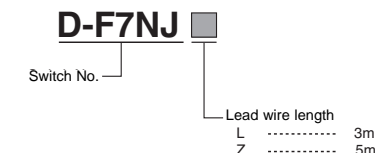

4.INTENDED CONDITIONS OF USE

Switch model number	D-F7NJL
Wiring	3 wire
Output	NPN
Application	Relay, Sequence control
Power voltage	24V DC (20 to 26V DC)
Current consumption	25mA or less
Load voltage	28V DC or less
Load current	40mA or less
Internal voltage drop	0.8V or less
Current leakage	100μA or less
Operating time	1ms or less
Indication light (Amplifier)	Operating range Red LED
	Most sensitive range Green LED
Impact resistance	Sensor : 1000m/s ²
	Amplifier : 300m/s ²
Ambient temperature	Sensor : 0 to 150 °C
	Amplifier : 0 to 60 °C
Protection structure	IEC60529 standard IP67

5.Names and Functions of Individual Parts

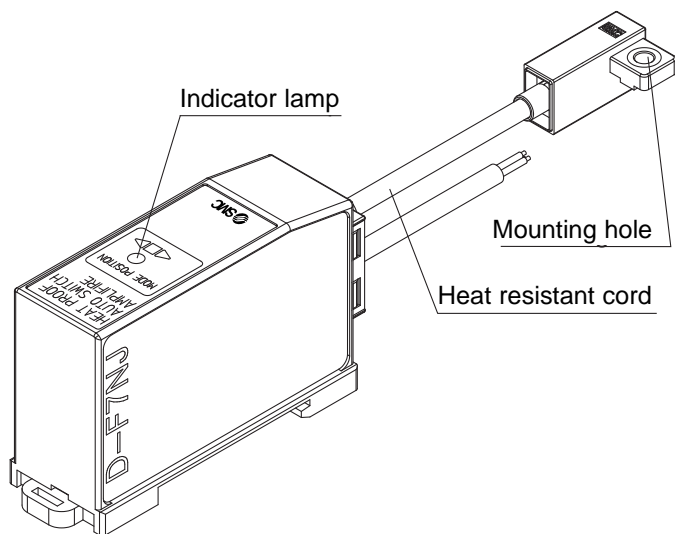

(Amplifier)

The Solid state switch amplifier unit should mounted on DIN rail.

How to mount on DIN terminal

As described below, hook the bottom of the body on the DIN rail, and then push and hold the unit down in direction of arrow. For removal, release the unit from the DIN rail using a screw driver.

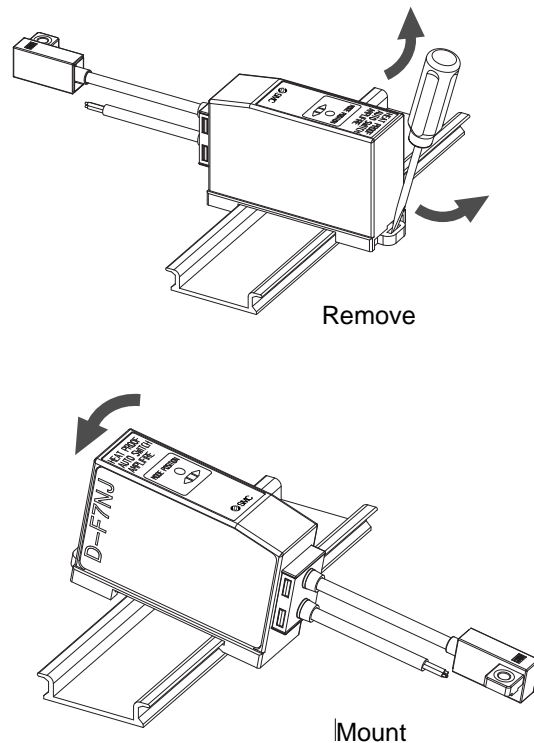

9.Check flow

When detection failure occurs(stay ON/OFF), please check based on the following flow chart.

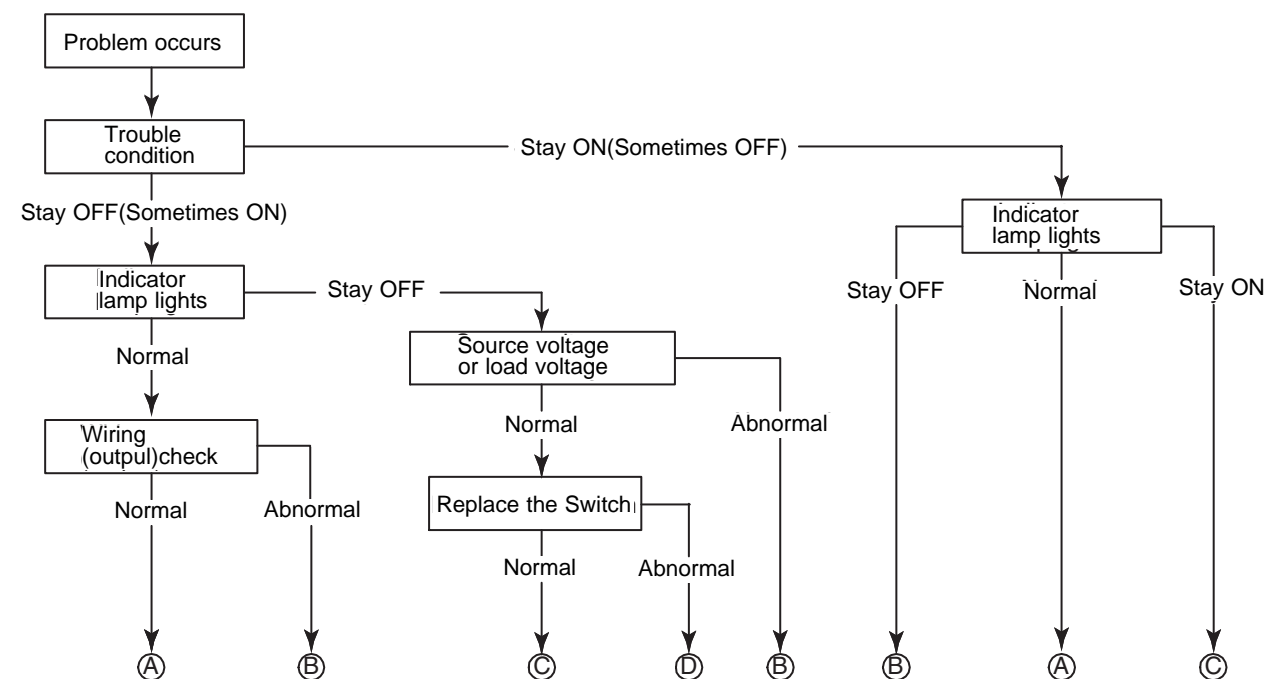

- Ⓐ --- Switch output failure (replace)
- Ⓑ --- Check and correct wiring
- Ⓒ --- Switch failure
- Ⓓ --- Replace actuator. Detectable magnet field not adequate (No magnet)

6.How to mount / Mounting bracket

(Sensor)

Each actuator has a specified mounting bracket when mounted to the auto switch. "How to mount/Mount bracket" depends on actuator type and tube I.D. Please refer to the actuator catalogue. When an auto switch is mounted for the first time, please ensure the actuator is of the magnet built-in type, then prepare brackets that correspond to the actuator. The application actuator : CDQ2 ※ ※ -XB14.

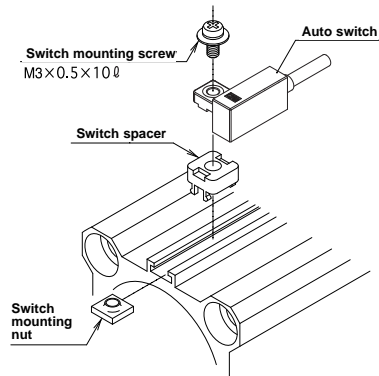

- ① Slide the auto switch mounting nut inserted into the mounting rail and set it at the auto switch mounting position.
- ② Fit the convex part of auto switch mounting arm into the concave part of auto switch mounting rail. Then slide the switch over the nut. (CDQ2 series:Fit the convex part of auto switch mounting arm through the auto switch spacer into the concave part of auto switch mounting rail.)
- ③ Push the auto switch mounting screw lightly into the mounting nut through the hole of auto switch mounting arm.
- ④ After reconfirming detection position, tighten the mounting screw to secure the auto switch. (Tightening torque of M3 screw should be 0.5 to 0.7N·m.)
- ⑤ Modification of the detecting position should be made referring to item ③

7.Basic wiring

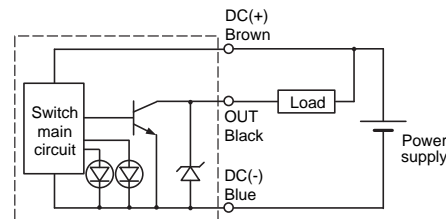

8.Exterior dimension

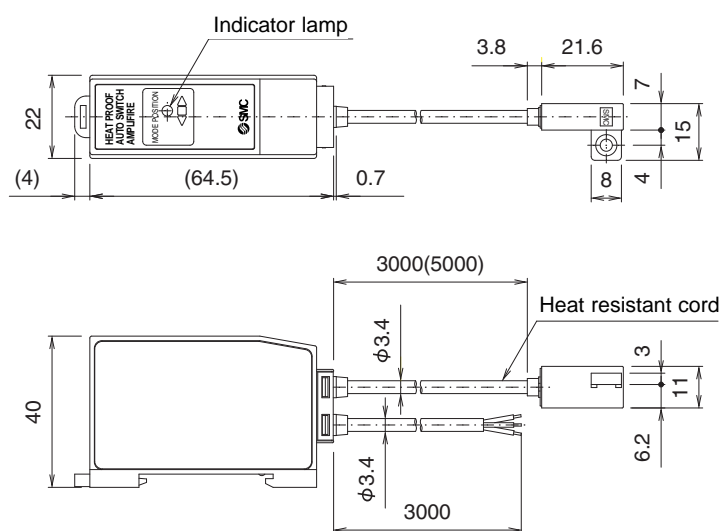

Manufacturer's batch marking

Year		Month	
Mark	Year	Mark	Month
J	2005	O	January
K	2006	P	February
L	2007	Q	March
M	2008	R	April
⋮	⋮	S	May
		T	June
		U	July
		V	August
		W	September
		X	October
		Y	November
		Z	December

□ When you inquire about the product, please contact the following.

SMC Corporation

URL <http://www.smcworld.com>

- Phone
- | | |
|--------------------------------|------------------------------------|
| AUSTRIA / (43) 2262-62 280 | ITALY / (39) 02-92711 |
| BELGIUM / (32) 3-355 1464 | NETHERLANDS / (31) 20-531 8888 |
| CZECH REP. / (420) 5-414 24611 | NORWAY / (47) 67 12 90 20 |
| DENMARK / (45) 70 25 29 00 | POLAND / (48) 22-548 50 85 |
| FINLAND / (358) 9-859 580 | PORTUGAL / (351) 2 610 89 22 |
| FRANCE / (33) 1-64 76 1000 | SPAIN / (34) 945-18 4100 |
| GERMANY / (49) 6103 4020 | SWEDEN / (46) 8-603 0700 |
| GREECE / (30) 1- 342 6076 | SWITZERLAND / (41) 52-396 3131 |
| HUNGARY / (36) 1-371 1343 | TURKEY / (90) 212 221 1512 |
| IRELAND / (353) 1-403 9000 | UNITED KINGDOM / (44) 1908-56 3888 |