



OPERATION MANUAL

SI unit

EX12#-SMB1

SMC CORPORATION

Contents

1. Safety instructions	-----	P3
2. Notes	-----	P6
3. Specifications		
3-1. General specifications	-----	P8
3-2. Electrical and network specifications	-----	P8
3-3. Applicable solenoid valve series	-----	P8
4. Wiring and setting		
4-1. Wiring communication line	-----	P9
4-2. Power supply line	-----	P9
4-3. Terminal board	-----	P9
5. Assignment of SI unit output No. and solenoid valve		
5-1. Standard wiring	-----	P10
5-2. Optional wiring (Single and double solenoid are connected)	-----	P10
6. LED display	-----	P10
7. Dimensions	-----	P11

1. Safety instructions

The SMC SI Unit Save-wire System and this manual contain essential information for the protection of users and others from possible injury and damage to property and to ensure correct handling. Please check that you fully understand the definition of the following messages (signs) before going on to read the text, and always follow the instructions. Also read carefully the instruction manual of relevant equipment or apparatus before use.

Indications

IMPORTANT MESSAGES	
Read this manual and follow its instructions. Signal words such as WARNING , CAUTION and NOTE , will be followed by important safety information that must be carefully reviewed.	
▲WARNING	Indicates a potentially hazardous situation which could result in death or serious injury if you do not follow instructions.
▲CAUTION	Indicates a potentially hazardous situation which if not avoided, may result in minor injury or moderate injury.
NOTE	Gives you helpful information.

Operator

- ◆ This operation manual has been written for those who have knowledge of machinery and apparatus that use pneumatic equipment and have full knowledge of assembly, operation and maintenance of such equipment.
- ◆ Please read this operation manual carefully and understand it before assembling, operating or providing maintenance to the SI Unit.

Usage Restrictions

◆ This product is designed for use in general equipment for factory automation. Never use this product with equipment or apparatus that directly concerns human lives*¹, or which malfunction or failure can cause a huge loss.

*1: Equipment or apparatus that directly matters human lives means the following:

- Medical equipment such as life support systems or equipment used in operating rooms
- Compulsory equipment required by law such as the Fire Prevention Law, Construction Law and etc.
- Equipment or apparatus that conforms with those mentioned above

◆ Contact our sales department when plans are made for the product to be used for the system*² including equipment that concerns itself with the safety of persons or that seriously affects the public. This usage needs special consideration*³.

*2: The system including equipment that concerns itself with the safety of persons or that Seriously affects the public means the following:

- Nuclear reactor control systems in nuclear power plants, safety protection systems or other systems important for safety in nuclear power facilities
- Driving control systems of mass transportation systems, and flight control systems
- Equipment or apparatus that comes into contact with foods or beverages

*3: Special consideration means discussing usage with our engineers to establish a safe system designed as fool-proof, fail-safe, redundant and etc.

◆ Special consideration of safety or maintainability should be taken to prevent hazard or loss caused by a failure or malfunction that is likely to occur in certain probability due to environmental stress (deterioration).

❖ The special consideration means to fully review the equipment or apparatus in design Stage and to establish a backup system in advance such as a redundant system or fail-safe system.

◆ Use for an interlocking circuit

When using the SI Unit as a sensor for interlock, adopt a double interlocking method such as equipping the mechanical protection function in order to deal with a SI Unit failure.

Check the SI Unit regularly to ensure proper operation.

⚠ WARNING

- ◆ Do not disassemble, modify (including change of printed circuit board) or repair.
An injury or failure can result.
- ◆ Do not operate the product beyond specification range.
Operation at a range that exceeds the specifications can cause a fire, malfunction, or damage to SI Unit.
Verify the specifications before use.
- ◆ Do not use the product in an atmosphere containing combustible, explosive or corrosive gas.
It can cause a fire, explosion or corrosion.
This SI Unit is not designed to be explosion-proof.
- ◆ A backup system in advance such as a redundant system or fail-safe system should be taken to prevent hazard or loss caused by a failure or malfunction that is likely to occur in certain probability.
- ◆ These instructions must be followed when using the product in an interlocking circuit:
 - Provide double interlocking by another system such as mechanical protection
 - Check the product regularly to ensure proper operationOtherwise malfunction can cause an accident.
- ◆ Perform maintenance regularly and verify the product is working properly.
Safety is not be assured due to unexpected malfunction.
- ◆ These instructions must be followed while in maintenance:
 - Turn off the power supply
 - Stop the supplied air, exhaust the residual pressure and verify the release of air before performing maintenance
electric capacitors or gravity force), verify the energy is reset to zero, and then perform maintenance work.Otherwise it can cause injury.

⚠ CAUTION

- ◆ Perform proper functional checks after maintenance.
Stop operation when an abnormality is observed such that the SI unit does not work properly.
Safety is not be assured due to unexpected malfunction.

2. Notes

Follow the instructions given below when designing, selecting and handling your SI Unit:

- ◆ The instructions on design and selection (installation, wiring, environment of use, adjustment, operation and maintenance) described below must also be followed.

* On Safety Standards

- When this product is incorporated to equipment or devices, proper measures shall be implemented at the equipment or device side when required by EMC Directives (Safety Standards) for its compliance.

* Product specifications

- Operate SI Unit with the specified voltage.
Operation with a voltage beyond specifications can cause malfunction or damage of the unit.
- Reserve a space for maintenance
Remember to leave space for maintenance when designing layout of the unit.
- Do not remove labels.
Otherwise error while in maintenance or misreading of an operation manual can cause damage or malfunction.
It may also result in nonconformity to safety standards.

- ◆ Instructions on handling

* Installation

- Do not drop, hit or apply excessive shock (100 m/s^2) to the unit.
Otherwise it can result in damage to the unit causing failure or malfunction.
- Follow the specified tightening torque.
Excessive tightening torque can break screws.
Refer to "3.Wiring and Setting" for installation.

* Wiring (including plugging in/out of connector)

- Do not bend or apply tensile force to cables, or apply force by placing heavy load on them.
Wiring with bending stress or tensile stress can cause breakage of the cables.
- Connect wires and cables correctly.
Miswiring can break the SI Unit depending on the miswired circuit .
- Do not connect wires while the power is on.
Otherwise it can break the SI Unit or I/O devices causing damage or malfunction.
- Do not lay wires or cables with power cable or high-voltage cable in the same wiring route.
Otherwise the wires to the SI Unit can be contaminated with noise or induced surge voltage from power lines or high-voltage lines causing malfunction.
Lay the wires to the SI Unit and out device to a wire duct or in a protective tube other than those for power lines or high- voltage lines.
- Verify the insulation of wiring.
Poor insulation (interference with other circuit, poor insulation between terminals and etc.) can introduce excess voltage or current to the SI Unit or out device causing damage.
- Separate power lines for solenoid valves from power line for Input and control unit.
Otherwise wires can be contaminated with noise or induced surge voltage causing malfunction.
- Take proper measurements against noise such as noise filter when the SI Unit is incorporated in equipment or devices.
Otherwise contamination with noise can cause malfunction.

***Environment**

- Select the proper type of protection according to the environment of operation.
IP65 protection is achieved when the following conditions are met.
 1. To connect units properly with power cable and cable with communication line.
 2. To install SI Unit and manifold valves properly.Use cover or etc. when install in an environment where water always splashes on these units.
- Take sufficient shielding measures when install at a following place.
Insufficient measures can cause malfunction or failure.
Verify the effect of the measures after installation of the unit in equipment or devices:
 1. A place where noise due to static electricity is generated
 2. A place where electric field strength is high
 3. A place where there is radioactive irradiation
 4. A place near power line
 5. A place where water splashes on the product.
- Do not use the product near by a place where electric surges are generated.
Internal circuit elements of the SI Unit can deteriorate or break when equipment generating a large surge (electromagnetic lifter, high frequency induction furnace, motor, etc.) is located near the SI Unit. Provide surge preventives, and avoid interference.
Use a solenoid valve equipped with surge absorber.
Direct drive of a load generating surge voltage can damage SI Unit.
- Prevent foreign matter such as remnant of wires from entering this product.
Take proper measures for the remnant not to enter the SI Unit in order to prevent failure or malfunction.
- Do not expose the SI Unit to vibration (less than 98 m/s^2) and impact (less than 100 m/s^2).
Otherwise it can cause failure or malfunction.
- Keep the specified ambient temperature range.
Otherwise it can cause malfunction.
Do not use SI Unit in a place where temperature suddenly changes even if it stays within the specified range.
- Do not expose the SI Unit to heat radiation from a heat source located nearby.
It can cause malfunction.

***Adjustment and Operation**

- Do not press any one of the setting buttons with a sharp object.
It can cause damage to the setting buttons.
Use precision screwdriver with small flat blade when setting DIP switches.

***Maintenance**

- Before performing maintenance, make sure to turn of the power supply, stop supplied air, release the residual air in the piping into the atmosphere, and verify that the pneumatic system is open to the air.
Otherwise an unexpected operation of a system component can occur.
- Perform maintenance and check regularly
Otherwise an unexpected malfunction of the system can occur due to a malfunction of the unit.
- Perform a proper functional check.
Stop operation when an abnormality is observed such that the device does not work properly.
Otherwise an unexpected malfunction of the system component can occur.
- Do not use solvents such as benzene, thinner or other to clean the SI Unit.
It can damage the surface of the body and erase the indication on the body.
Use a soft cloth to remove stains. For heavy stains, use a cloth soaked with diluted neutral detergent and fully squeezed, then wipe up the stains again with a dry cloth.

3. Specifications

3-1. General specifications

Item	Specifications				
Type	EX120 -SMB1	EX121 -SMB1	EX122 -SMB1	EX123U/D -SMB1	EX124U/D -SMB1
Operating ambient temp.	0 to +55°C (Max. 8 points ON) 0 to +50°C (All the points ON)				
Operating ambient humidity	35 to 85%RH (No dew condensation)				
Storage ambient temp.	-20 to +65°C				
Vibration proof	50m/s ²				
Impact proof	100m/s ²				
Noise immunity	±1000 V p-p Pulse 1μs Stand up 1ns				
Withstand voltage	AC1000V 50/60Hz for 1 min. between FG and external terminal package.				
Insulation resistance	More than 2MΩ between FG and external terminal Package.(with DC500V insulation tester)				
Operating environment	No corrosive gas				
Weight	110g	140g	130g	240g	240g
Protection class	IP20			IP65	

3-2. Electrical and network specifications

Item	Specifications				
Type	EX120 -SMB1	EX121 -SMB1	EX122 -SMB1	EX123U/D -SMB1	EX124U/D -SMB1
Applicable system	MELSECNET/MINI-S3 (MITSUBISHI ELECTRIC Corp.)				
Output points	16 points				
Output style	NPN open collector type				
Connect load	Solenoid valve for 2.1W or less with ramp surge voltage protection circuit.				
Residual voltage	0.4V DC or less				
Source voltage	Unit	24VDC+10%, -5%			24VDC ±10%
	Solenoid valve				24VDC +10%, -5%
Current consumption	0.1A or less (Inside of the unit)				
Occupied station	2 stations				

3-3. Applicable solenoid valve series

SI unit	Valve series
EX120-SMB1	VQ1000, VQ2000, SV1000, SV2000, SV3000, SV4000
EX121-SMB1	VQ1000, VQ2000, SX3000, SX5000, SY3000, SY5000
EX122-SMB1	SX3000, SX5000, SY3000, SY5000
EX123U/D-SMB1	VQ2000, VQ4000
EX124U/D-SMB1	VQ2000, VQ4000

See solenoid valve catalogue for details.

4. Wiring and Setting

4-1. Wiring communication line

Wire the twist pair cable as in the drawing below. Ground the shield wire at one point at receiving side or sending side.

Recommended cable for wiring is Mitsubishi electronics corp. cable.

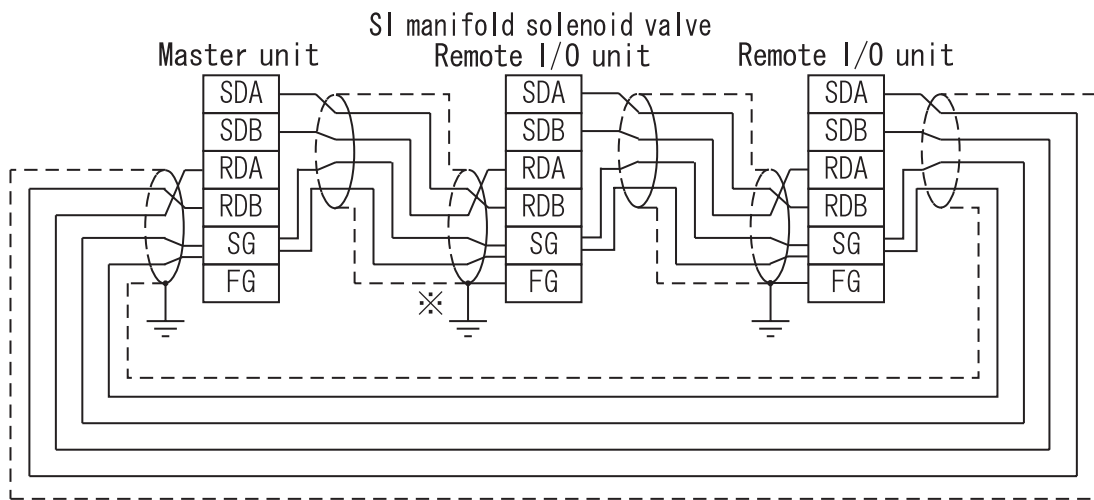

※ Ground the shield wire at one point at receiving side or sending side.

4-2. Power supply line

Connect power source within the specification range.

Decide the power source and the connect cable according to the power consumption of the solenoid valves and SI unit.

4-3. Terminal board

Terminal description	Connect to...
24V	Supply source 24V
0V	Supply source 0V
SDA	RDA of next station
SDB	RDB of next station
SG	SG of previous and next station
RDA	SDA of previous station
RDB	SDB of previous station
FG	Ground wire and shield wire
0V (note1)	Supply source 0V (for solenoid valve)
24V (note1)	Supply source 24V (for solenoid valve)

Note1) Applicable for EX124U/D-SMB1 only

Warning

During wiring, turn off the power of the unit and all the equipment connected to the unit.

Tighten the wire securely with the terminal screw. It has to be M3 screw.

Use the crimp terminal appropriate for the terminal screw. Inadequate tightening lead to cause short circuit, fire accident and malfunction.

Choose appropriate power source with adequate power capacity.

5. Assignment of SI unit output No. and solenoid valve

5-1. Standard wiring

SI unit output is numbered numerically in ascending order from the solenoid valve of D side. SI unit has D side and U side for mounting. Some solenoid valves have only one side for mounting.

See the catalogue of solenoid valve for details.

Wiring is double for all the internal wiring of manifold in case of both VQ and SX manifold solenoid valve with 8 stations or less.

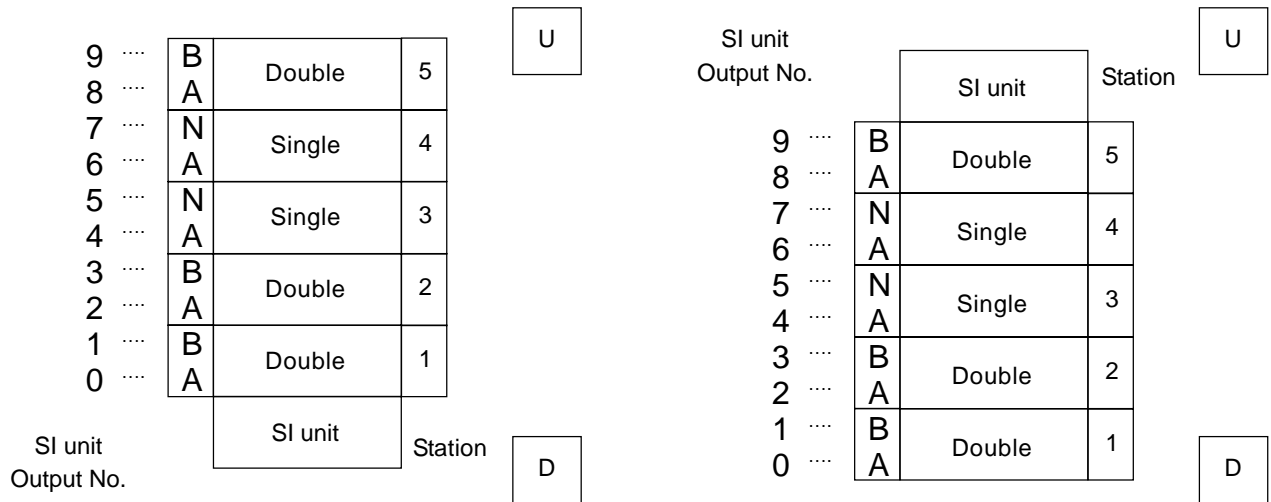

5-2. Optional wiring(Single and double solenoid are connected)

As an option, wiring can be mixed with single and double together. This is specified based on the type of the solenoid valve.

For this option, please specify the wiring spec. in the manifold solenoid valve specification.

Address assignment

Cut the power supply during address assignment.

Open the cover, and rotate the switch with flat blade driver to assign them.

Setting range is 1 to 64. Since SI unit occupies 2 stations, the assignment goes like 1, 3, 5...63.

Although address can be assigned regardless of connecting order, don't leave the interval. Address can not be assigned overlapped.

6. LED display

LED description	Turn on when...
POWER	Power applied
RUN	Data transmitted properly with the master station
SD	Turns on slightly while data sent(Blinks rapidly)
RD	Turns on slightly while data received(Blinks rapidly)
ERR	Data receiving error occurred. Turned on when communication back to normal

6. Dimensions

EX120-SMB1

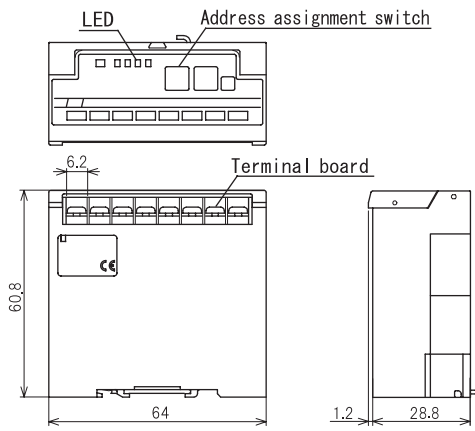

EX123U/D-SMB1

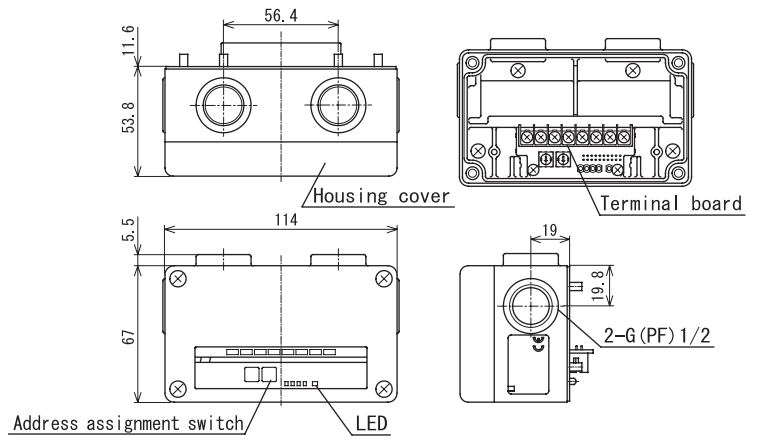

EX121-SMB1

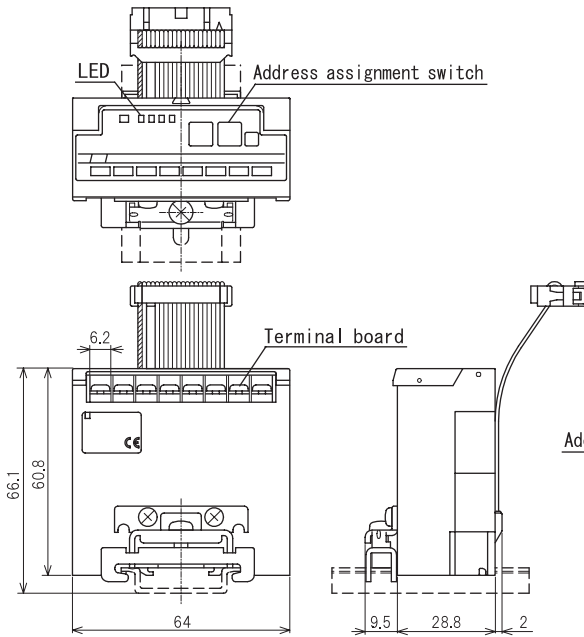

EX124U/D-SMB1

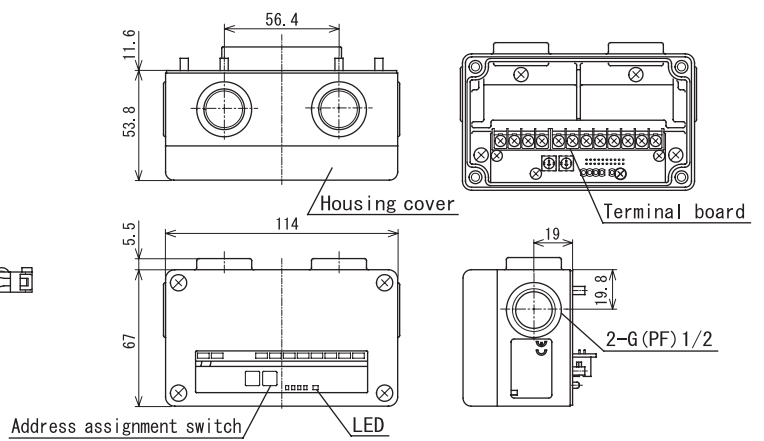

EX122-SMB1

