



Instruction Manual

SI Unit / DI Unit

EX240-SDN2

EX240-IE1

SAFETY INSTRUCTIONS

(Read carefully before use.)

Thoroughly read this technical instruction manual and related manuals mentioned here to ensure the safety and proper operation of the product.

Level of potential hazard



Warning: Operator error could result in serious injury or loss of life.



Caution : Operator error could result in injury or equipment damage.



Caution

Thoroughly read this manual

Thoroughly read this manual and operate the product within the specified range following every instruction.

Handle with care

Do not drop the product and/or give excessive impact on the product.

Keep the specified voltage range

An operation error, breakage, electric shock and fire may occur if the product is operated with voltage out of the specification.

Do not touch terminals and/or internal circuit board while they are energized

An operation error, breakage or electric shock may occur if you touch energized terminals and/or internal circuit board.

Keep the ambient temperature specification

Use within the specified ambient temperature. Do not use the product in an atmosphere subject to a sudden temperature change even if the temperature is within the specified range.

Avoid foreign matter from getting inside the product

Make sure that foreign matter such as bits of wire does not enter the product. It may result in a fire, failure or operation error.



Warning

The product is designed to use in ordinary full automation equipment. Prevent the use in machinery and/or equipment where human life may be directly injured and malfunction or failure may cause enormous loss.

Do not disassemble the product for maintenance or modifications.

CONTENTS

1 Outline	2
2 Part numbers	2
3 System components.....	2
4 Appearance	3
5 Connector.....	4
5.1 Power supply connector.....	4
5.2 Communication connector	4
5.3 Input connector	5
6 Display.....	5
7 Wiring	6
7.1 Power supply wiring	6
7.2 Connection style.....	7
7.3 Input wiring	8
8 Solenoid valve.....	9
9 Setting	10
10 Specifications	12
11 Dlagnois	14
12 Input/Output No. assignment	15
13 Installation & Maintenance	17
14 Troubleshooting	19

1 Outline

A Network which is compatible and exchangeable with equipment from various manufacturers since communication specifications are opened.

Serial interface unit (SI unit) for DeviceNet

As a slave of DeviceNet, it is possible to control switching (ON/OFF) of solenoid valves up to 32 points. This distributed I/O device also allows sensor signals for the maximum of 32 points to be input (digital input) by connecting discrete input unit. IP65 is satisfied.

Discrete input unit (DI unit)

An expansion unit to input with sensor such as auto switch by connecting to SI unit. Each DI unit is able to take sensor input up to 8 points and set it to sensor by using NPN/PNP change-over switch. Up to 4 pieces of DI units can be attached to SI unit for expansion. IP65 is satisfied.

2 Part numbers

EX240 - SDN2
EX240 - IE1
EX240 - EA1

SI unit for DeviceNet (NPN output)
8 point - input DI unit
End case assembly

3 System components

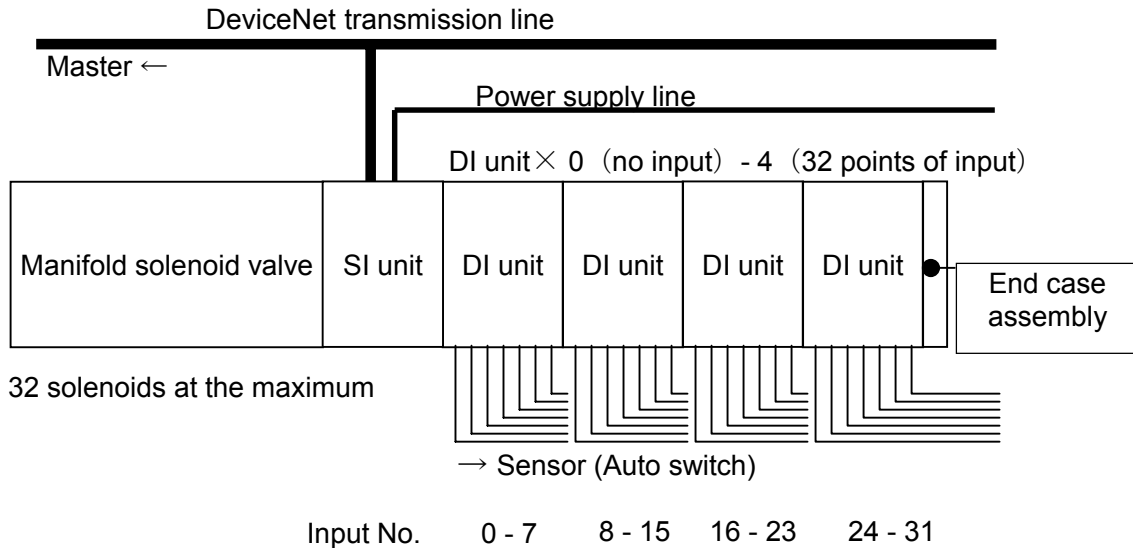

4 Appearance

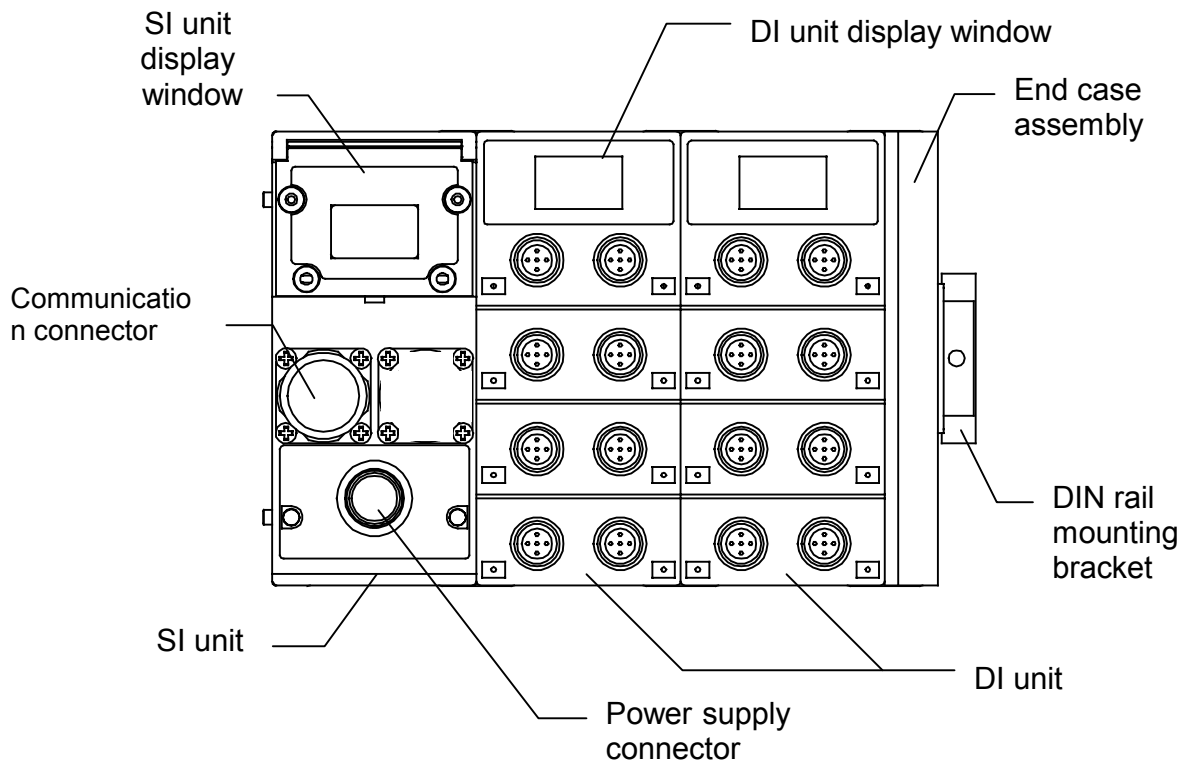

5 Connector

5.1 Power supply connector

Franz Binder Series 723 5 pins (72309-0115-80-05)

Connector example for cable: Franz Binder 72309-0114-70-15
Amphenol C091AT 3361 001

※DIN type 5 pins

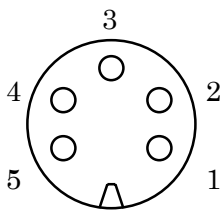

No.	Description	Function
1	SV24V	+ 24V for solenoid valve
2	SV0V	0V for solenoid valve
3	PE	Protection earth
4	SW24V	+ 24V for Sensor unit
5	SW0V	0V for Sensor unit

5.2 Communication connector

OMRON M12 5 pins (For DeviceNet only)

Connector example for cable: OMRON DCA1-5CN05F1
KARL LUMBERG RKT5-56

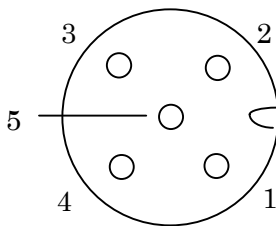

No.	Description	Function
1	Drain	Drain/Shield
2	V+	Power for line +
3	V-	Power for line -
4	CAN_H	Signal line H
5	CAN_L	Signal line L

※Compatible with Micro Style connector with DeviceNet specifications

5.3 Input connector

M12 5 pins (compatible with OMRON XS2F) × 8 pcs.

Connector example for cable: OMRON XS2G

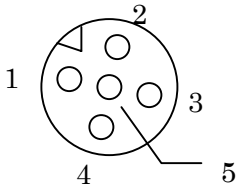

No.	Description	Function
1	SW+	Supply power + for sensor
2	N.C	Free※
3	SW-	Supply power - for sensor
4	SIGNAL	Sensor input signal
5	PE	Protection earth for sensor

※ No.2 pins of connectors with input No. 0, 2, 4, and 6 (connectors on the right side of each DI unit) are internally connected to No.4 pins of input No.1, 3, 5 and 7 (sensor input signals), respectively.

This allows direct input for 2 points which are put in one cable with a collective connector.

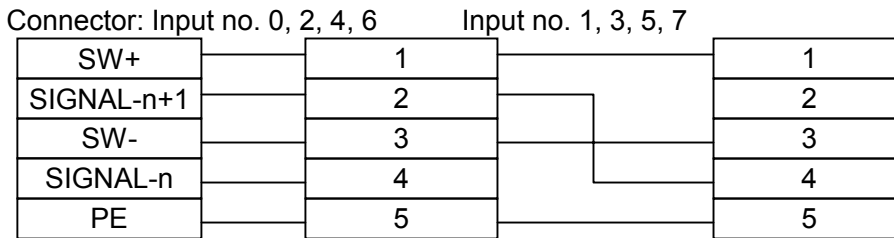

NOTE: Use water-proof cover on unused input connectors in case protection structure is necessary equivalent to IP65. Please order the water-proof cover separately.
Ex: OMRON XS2Z-12

6 Display

SI unit

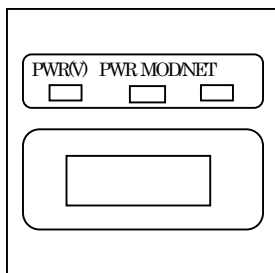

Descp.	Function
PWR(V)	Lights up when power for solenoid valve is supplied
PWR	Lights up when power for DeviceNet line is inputted
MOD/NET	Lights off: power off, off line, or duplicate check MAC_ID
	Green flashing: waiting for connection (online)
	Green lights up: connection completed (online)
	Red flashing: connection time-out (light degree of communication error)
	Red lights up: MAC_ID duplicate error, or BUSOFF error (Heavy degree of communication error)

DI unit

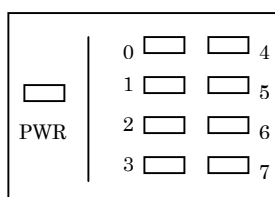

Descp.	Function
PWR	Lights up when power for sensor is supplied. Lights off when short-circuit suppressor works.
0~7	Lights up when each sensor input turns on.

7 Wiring

7.1 Power supply wiring

Power supply line inside the unit has individual power supplies for solenoid valve actuation (SV power supply) and for Sensor (SW power supply). Supply DC24V for each of them. Either single or individual power supply is available. Wiring is not necessary for SW power supply when input unit is not used.

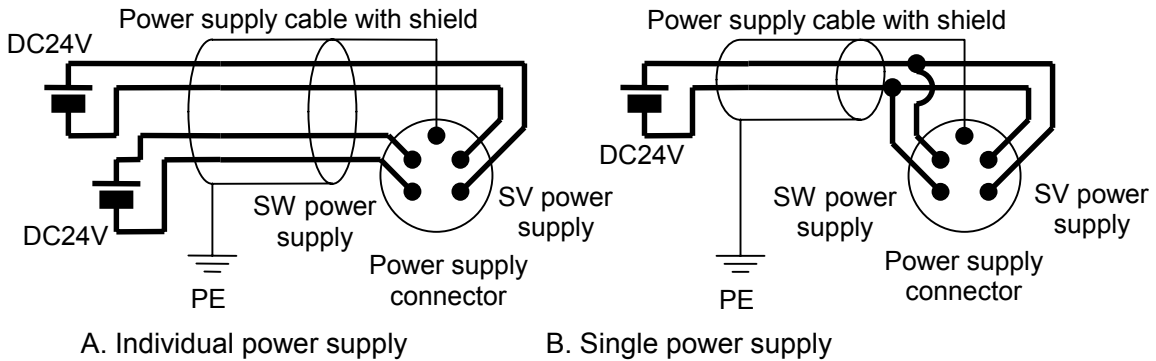

Power for sensor is supplied to sensor connected with DI unit. Select sensor concerning voltage drop up to approx. 2V inside the unit at this moment. If sensor requires 24V, it is necessary to lower power supply voltage for sensor slightly or secure power supply for sensor separately without going through SI unit so that sensor input voltage can be 24V with actual loading (allowable voltage of sensor power supply: 19.2V to 28.8V).

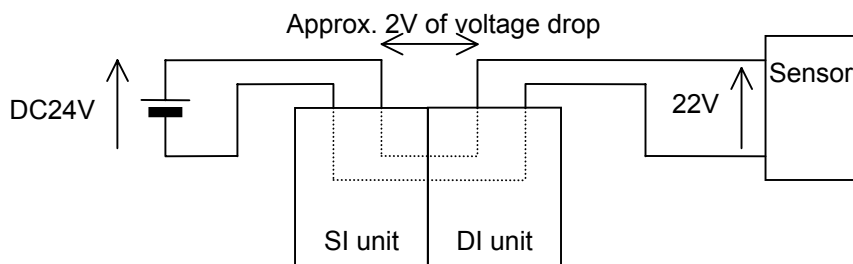

Select power supply cable sufficient for power consumption and number of stations of solenoid valves, and current consumption of SI unit and sensor.

Wire power supply cable to plug properly and then connect it to socket of SI unit.

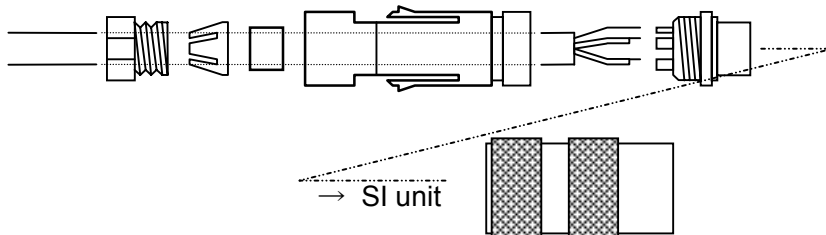

FRANZ BINDER 72309-0114-70-05

7.2 Connection style

T branch, multi branch, branch line branch, and multi drop connections are available for DeviceNet. Longitudinal extension of main and branch line are different depending on the communication speed.

Also, it is different depending on thick and thin line of communication cable, please refer to following table.

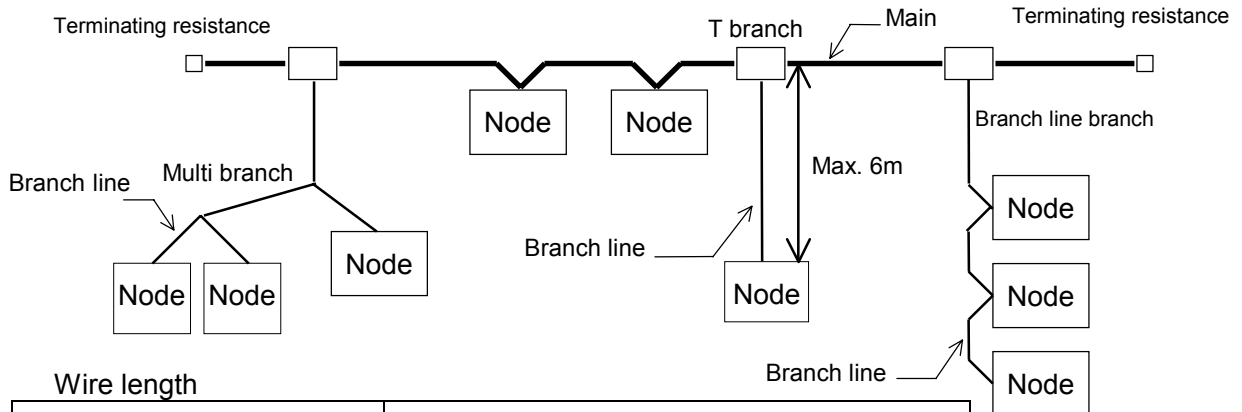

Wire length		Communication speed (kbps)		
		125	250	500
Max. length of Network	Thick cable	500m or less	250m or less	100m or less
	Thin cable	100 or less		
Total length of branch line		156m or less	78m or less	39m or less
		Note: Max. length of a branch line is up to 6m.		
Terminating resistance		121 Ω (1/2w)		

Cable specifications

Item	Thick line		Thin line	
	Signal	Power	Signal	Power
Conductor cross section	0.82mm ²	1.65mm ²	0.20mm ²	0.33mm ²
Color	Blue, White	Red, Black	Blue, White	Red, Black
Impedance	120 Ω ± 10%	--	120 Ω ± 10%	--
Propagation delay	1.36ns/ft	--	1.36ns/ft	--
Attenuation factor	500KHz: 0.25dB/ft 125KHz: 0.13dB/ft 1.00MHz: 0.40dB/ft	--	500KHz: 0.50dB/ft 125KHz: 0.29dB/ft 1.00MHz: 0.70dB/ft	--
Conductor resistance	6.9 Ω /1000ft	3.6 Ω /1000ft	28 Ω /1000ft	17.5 Ω /1000ft



Wiring Instruction

- Please prepare plug connector for T type branch at customer in order to have multi drop connection. (Ex. TMSTBP 2.5-STF-5.08 Phoenix Contact Co., Ltd.)
- Use connection cable for DeviceNet cable.
- The terminating resistor for DeviceNet should be used at the both end of mains.

7.3 Input wiring

Input connector allows connection with plug for M12 sensor of the following specifications.

No. of pins	4 or 5 pins
AC / DC	DC

NOTE: Use water-proof cover on unused input connectors in case protection structure is necessary equivalent to IP65. Please order the water-proof cover separately.
Ex: OMRON XS2Z-12

Input circuit diagrams

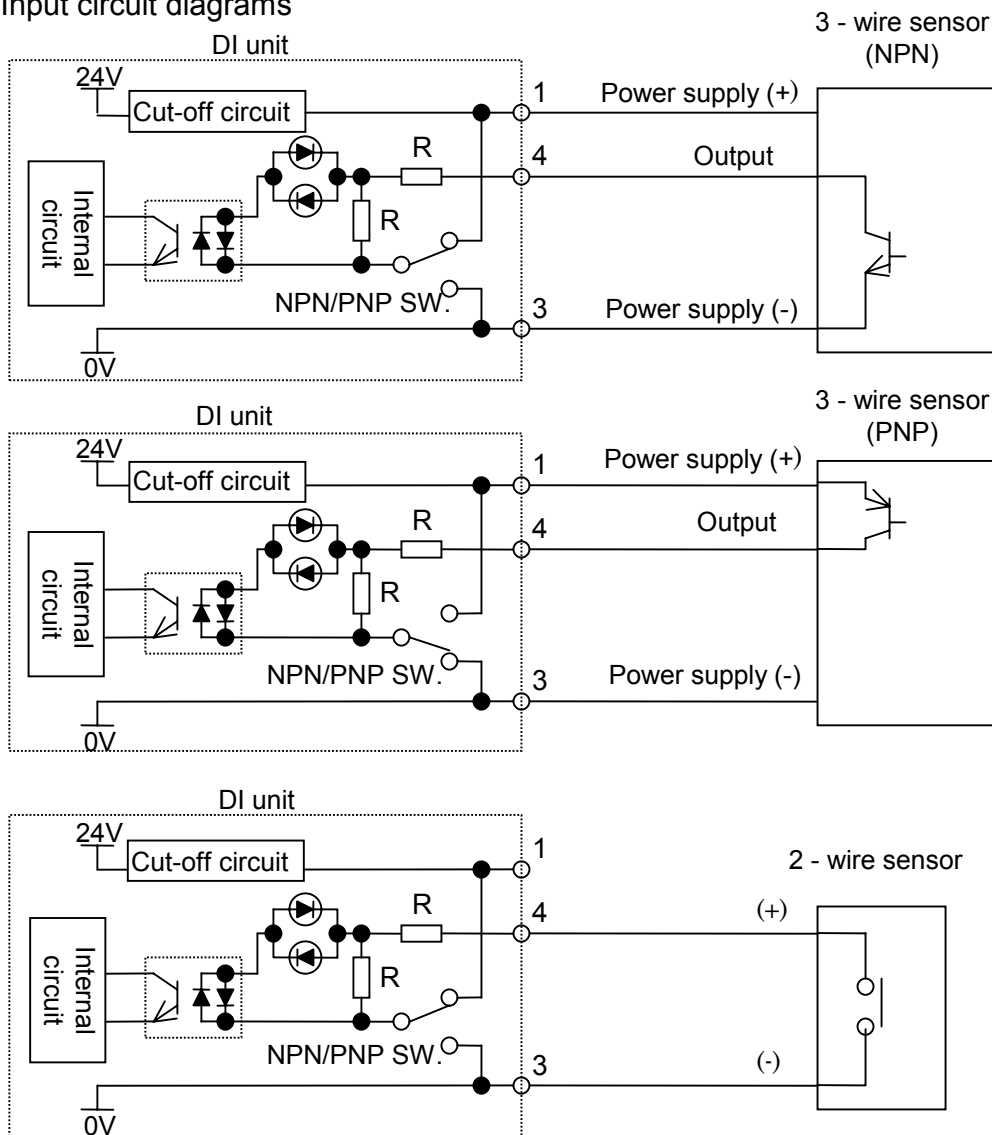

※ Allowable supply current for sensor is 500mA per DI unit at the maximum. For DI unit to which 8 pieces of sensors are connected, approximately 60mA can be supplied per point.

If excessive current flows into sensor power supply due to short circuit, power supply is stopped by cut-off circuit. In such a case, solve the problem, cut power once and then supply it again for return.

- Example of sensor connection

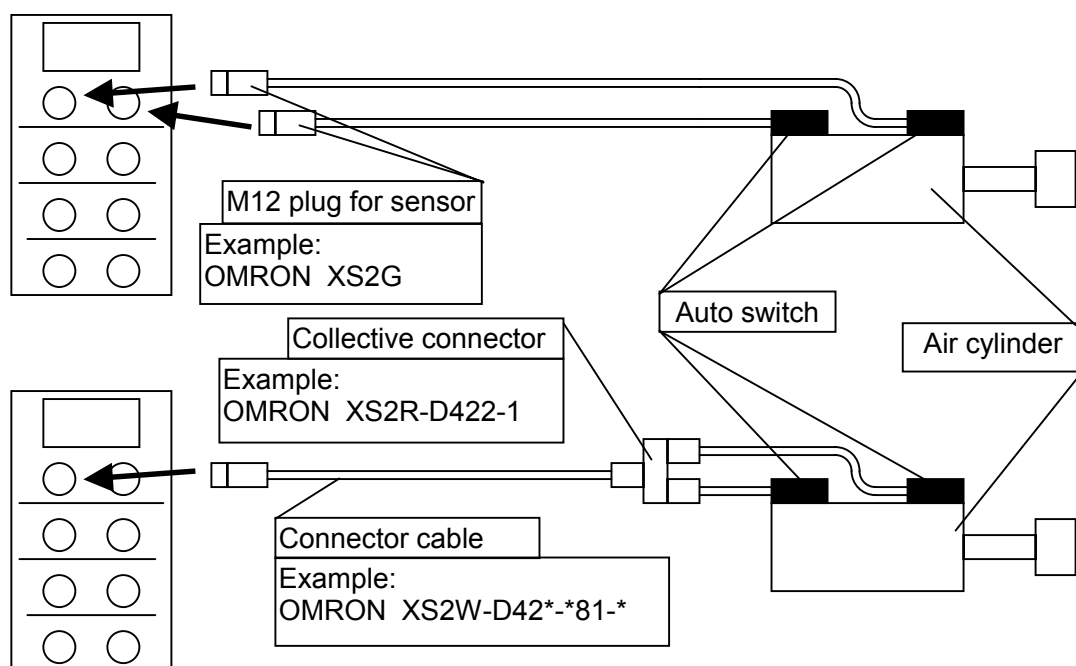

8 Solenoid valve

Part numbers of manifold solenoid valves which can be connected to SI unit are shown below.

Series
VQ2000
VQ4000
VQC4000

How to order

- Series VQ (in case of VQ2000)

V V 5 Q 2 1 - 0 8 C 6 S D Q W 4 * - W

For D side mounting

For DeviceNet

No. of input units

IP65

Input unit specification

- Series VQC (in case of VQC4000)

V V 5 Q C 4 1 - 0 8 C 6 S D Q W 4 *

For DeviceNet

No. of input units

Input unit specification

For details, such as manifold specifications, refer to catalogues and materials of each manifold solenoid valve.

9 Setting

DIP switch setting

※Power of SI unit should be turned off while setting the DIP switch.

DIP switch

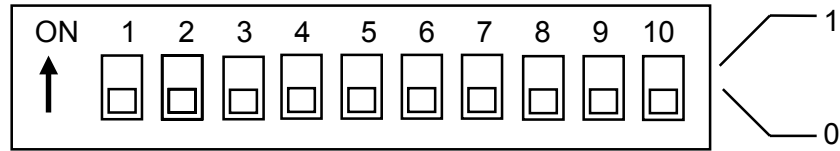

● Address setting

Address	SW.1	SW.2	SW.3	SW.4	SW.5	SW.6
	1	2	4	8	16	32
0	0	0	0	0	0	0
1	1	0	0	0	0	0
2	0	1				
...						
62	0	1	1	1	1	1
63	1	1	1	1	1	1

● Mode setting

0	HW mode
	Set address and communication speed by SW.1~8.
1	SW mode
	Set address and communication speed via network. ※ SW.1~8 is invalid.

● Communication speed setting

communication speed	SW.7	SW.8
125kBPS	0	0
250kBPS	1	0
500kBPS	0	1
unused	1	1

● Output setting at communication shutdown

SW.9	Output condition of solenoid valve at communication shutdown (I/O connection · time out), fault · message
1	All output hold (Fault action=1 · Fault value=0)
0	All output clear (Fault state=0 · Fault value=0)

※NOTE

- Node address 63 · communication speed 125kBPS is set at delivery (Both HW mode and SW mode) .
- Address and communication speed set at SW mode is maintained even after power of SI unit is turned off. Also, when turning on power at HW mode, address and communication speed set at SW mode is deleted and address and communication speed set by switch is memorized.

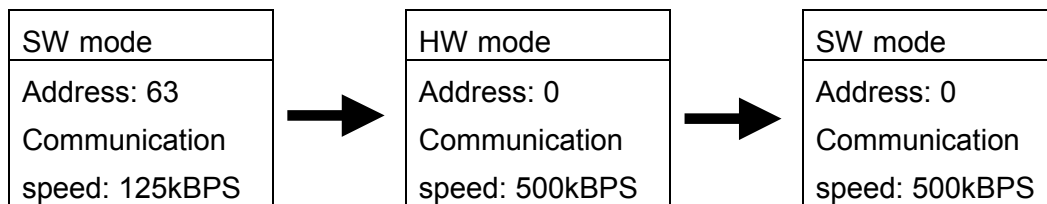

- Output setting for communication shutdown is 0 (all output clear mode) at delivery. Further, output setting for communication shutdown is possible to change the setting individually for 1 point via network of DeviceNet. In this case, setting of SW.9 is invalid.

Input circuit setting

It is possible to change input circuit setting (NPN / PNP sensor input) for every DI unit. Disconnect DI units each other and set them individually. See “12. Installation & Maintenance” for disconnection and connection of units.

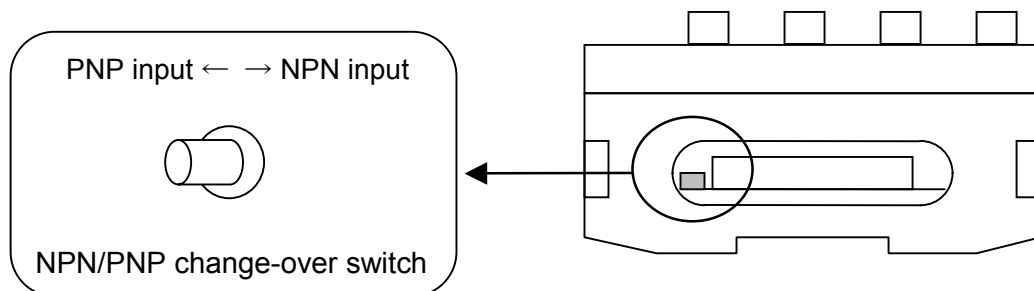

10 Specifications

Communication specifications

Protocol	DeviceNet Release2.0
Communication speed	125k, 250k, 500kbps
MAC ID setting range	0~63
Slave (branch) type	Group2 Only Server
Input	32 points (not depend on number of DI units)
Output	32 points (not depend on points of solenoid valves)
Device information	Device type : 27 (Pneumatic valve) Product code : 2401 Vendor ID : 7 (SMC Corp.)
Corresponding message	Explicit Polled IO

General specifications

	EX240-SDN2	EX240-IE1
Dimension (W×H×D)	54×88.5×120 *1	54×72.4×120 *1
Weight	400g *1	370g *1
Ambient temperature	0~50°C	
Ambient humidity	30~95%RH (without condensation)	
Applicable altitude	Less than 1000m above sea	
Vibration proof	10~57Hz 0.35mm (constant amplitude)	
	57~150Hz 5G (constant speed)	
Shock resistance	Peak value : 15G / 11ms 3 times each in directions of ± X,Y and Z	
Enclosure	IP65	

*1) Attachments excluded.

Electrical specifications

Rated voltage	DC24V
Power supply voltage	Power supply for solenoid valve : 21.6~26.4V (warning of voltage drop given at approx. 19V)
	Power supply for SI units: 11~25V
	Power supply for DI unit: 19.2~28.8V
Current consumption	Power supply for solenoid valve : depends on solenoid valve specifications and number of stations.
	Power supply for SI/DI units : 200mA (at Min. power supply voltage for SI unit) + sensor supply current
Withstand voltage	AC1500V 1min. (between PE – external terminal package)
Insulation resistance	10M Ω or more (DC500V meg. between PE – external terminal package)
Momentary power failure	1ms (power supply for SI/DI units)
Applicable load	solenoid valve with 2.1W or less of light and surge voltage suppressor
Driving current / Residual voltage	100mA / 0.3V Max. (at ON)
Driving circuit	N-ch MOS-FET open drain

Input specifications

Standard	IEC1131-2
Corresponding sensor	Current source type (PNP output) Current sink type (NPN output) *1
Rated voltage Ue	DC24V *2
Logical "1" input voltage UH	11~30V
Logical "0" input voltage UL	-3~5V
Logical "1" input current IH	8mA Typ.
Connection of 2-wire type sensor	Possible
Logical "0" allowable current IL	2.5mA Max.
Input delay	3ms Typ.
Sensor supply current	500mA / DI unit (60mA Max. / sensor)
Short circuit suppressor	600mA Typ. for each SI unit (supply power cut) Cut power once and then supply it again for return.

*1) Changed over by switch (for every DI unit)

*2) Approx. 2V of voltage drop for power supply voltage (power supply for SI/DI units)

11 Diagnosis

The EX240-SDN2 has two options to notify the state of the solenoid valve power supply voltage. In addition, the EX240-SDN2 can notify the state of the input over current via input data as in the case of the below special mode setting.

First option (Standard mode setting, Default)

Once the SI unit detects that the solenoid power is down (19V or less), the SI unit stops communication to notify the PLC that the SI unit has a certain problem (an insufficient power).

In this standard mode setting, you can monitor the state of the input over current by the LED on the input unit. Refer to page 5 of this manual.

Note) In this standard mode setting, input data will freeze once the SI unit detects that the solenoid power is down and will stop communication. If you want to maintain the input data when the solenoid power is down, we recommend the below second option.

Second option (Special mode setting)

This mode can be set using the DIP switch accessible from the right side of EX240 serial unit. With the switch position set to “1” (ON), the serial unit can communicate continuously regardless of the solenoid power condition (with the switch position set to “0” (OFF), the serial unit will lose communication if the solenoid power falls below specifications). The default DIP switch setting is all bits OFF. In this special mode setting, the serial unit can notify the PLC of the solenoid valve power state and input unit over-current status via input data.

However, special configuration is required. Configure your system for 6 bytes inputs and 4 bytes outputs instead of 4 bytes/ 4 bytes. This makes it possible to monitor solenoid valve power state and input over-current state of the input register. You can also monitor input unit over-current status by LED on the input unit. Refer to page 5 of this manual.

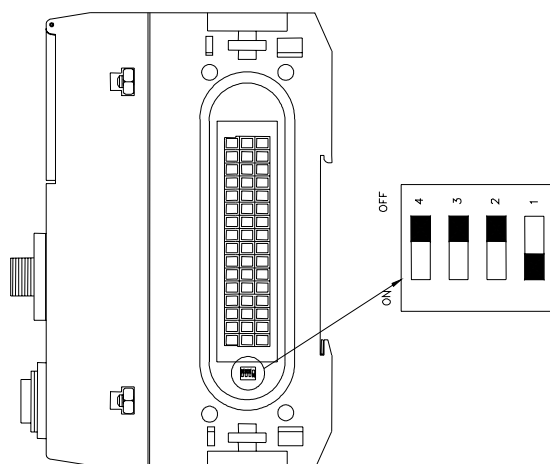

OFFSET	BIT							
	7	6	5	4	3	2	1	0
0	Sensor capture data							
1								
2								
3								
4	Reserved							
5	Reserved				DI	SOLV	Reserved	

SOLV: Solenoid valve power status (0: power is abnormal (19VDC or less), 1: power is normal (24VDC +10%, -5%))

DI: Over current status of input units (0: over current detected, 1: unit is normal)

12 Input / Output No. assignment

● SI unit input/output data (Poll command send/receive data)

Item		Output (Poll request)	Input (Poll response)
Occupied byte		4 byte (solenoid valve output)	4 byte (sensor input)
send/receive data	Address+0	Output No. 0~7	Input No. 0~7
	Address+1	Output No. 8~15	Input No. 8~15
	Address+3	Output No. 16~23	Input No. 16~23
	Address+4	Output No. 24~31	Input No. 24~31

*) Assignment method of send/receive data is different by PLC.

Refer to the PLC master (scanner) manual for the detail.

Correspondence between output data and solenoid valve

Output data

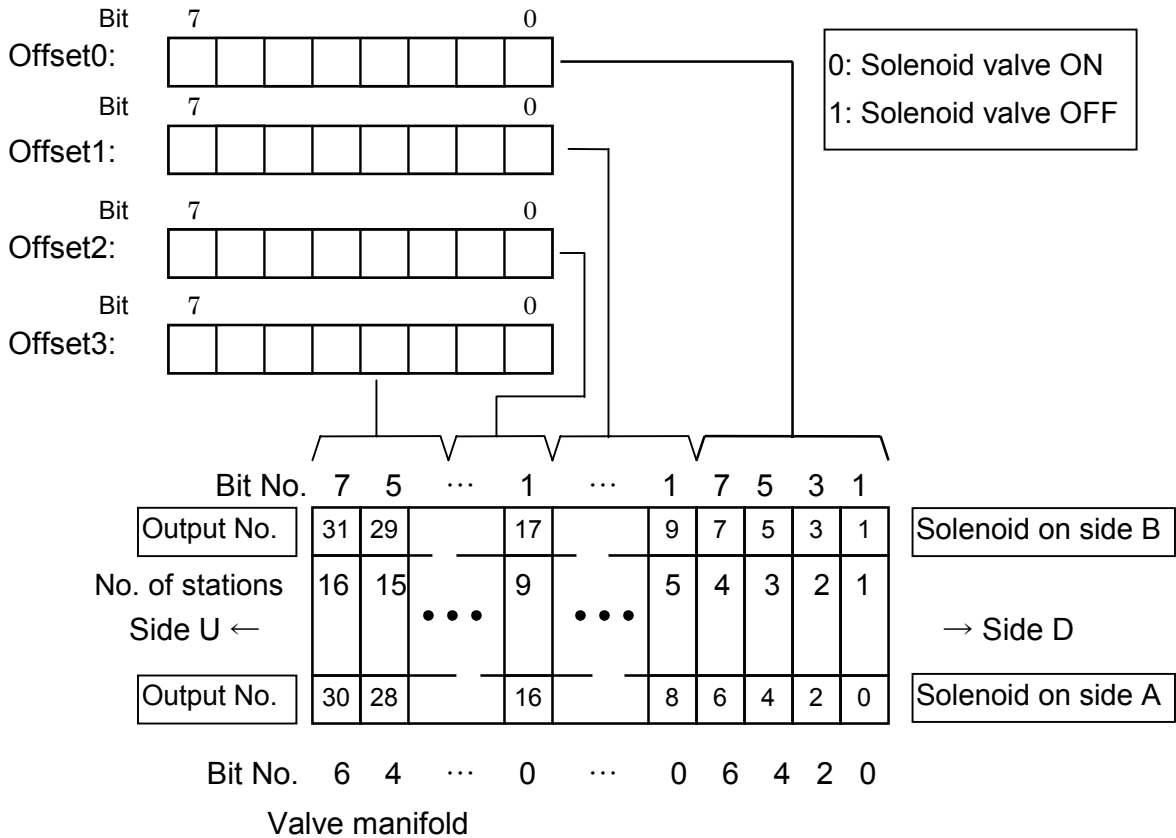

※ Output numbers are assigned to stations from side D to U of manifold in order (See manual of each manifold solenoid valve for the directions of side D and U.)

※ Standard manifold is wired in double.

Output numbers are assigned to side A and B alternatively. In case of single solenoid valve, output on side B is free.

	Station		
	No.	no.	No.
Double	4	3	5
Single	2	2	3
Double	0	1	1

Free

※ Mixed (single and double) wiring is available as long as wiring specifications designate it. This allows output numbers to be specified without having free output.

	Station		
	No.	no.	No.
Double	3	3	4
Single	2	2	-
Double	0	1	1

※ Each bit of data sent from master (4 bytes) shows ON/OFF (0: OFF, 1: ON) of solenoid valve. Starting from LSB of the first byte (Offset0), output numbers are assigned to all the bits in numeric order.

13 Installation & Maintenance

Installation

- ① Fix DIN rail for mounting SI/DI unit to the position where the unit is installed.
- ② Set SI/DI units on DIN rail and fix them with mounting brackets.

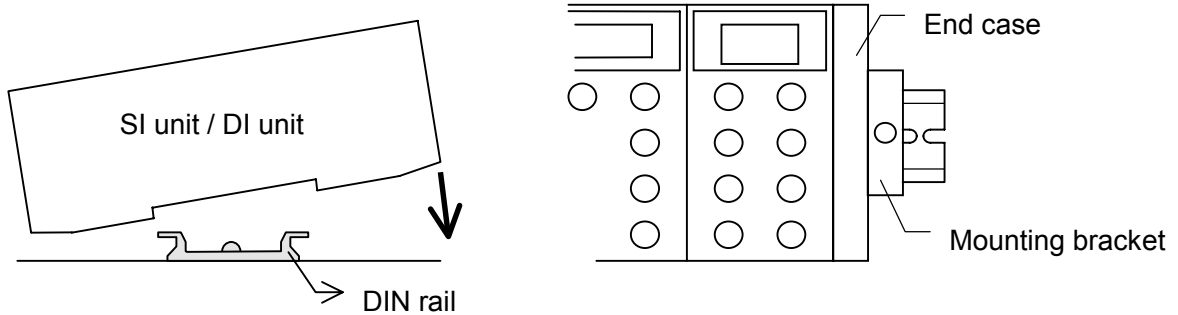

- ③ Fix manifold solenoid valve with mounting screws.
- ④ Ground PE (protective earth) terminal (Type 2 installation).

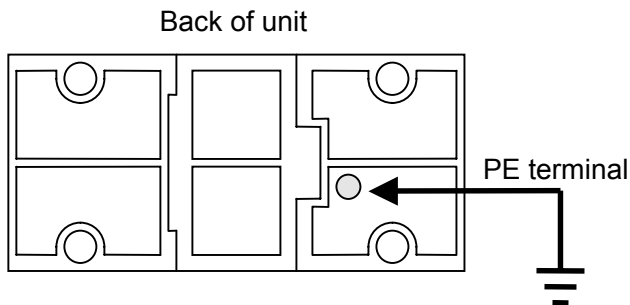

- ⑤ Arrange wires (for power supply, communication and input) and pipes.

Unit expansion and disassembly

- Disconnect units each other by loosening screws of modular adapter.
- Slide unit in lateral direction for disassembly in condition that modular adapter is unscrewed.
- Follow the same procedure to separate manifold - SI unit and SI/DI units - end plate.

- For connection by the unit, follow the procedure backwards. Make sure that joint is properly set. If not, liquid and particles may enter the inside of unit.

Check the following points to confirm proper joint setting.

- ① No missing joint.
- ② No breakage, falling and twist in joint packing.
- ③ No foreign matter adhered.
- ④ No inclined mounting.

- Keep tightening torque specification for modular adapter. If tightening torque is insufficient or modular adapter is inclined, liquid and particles may enter the inside of unit.

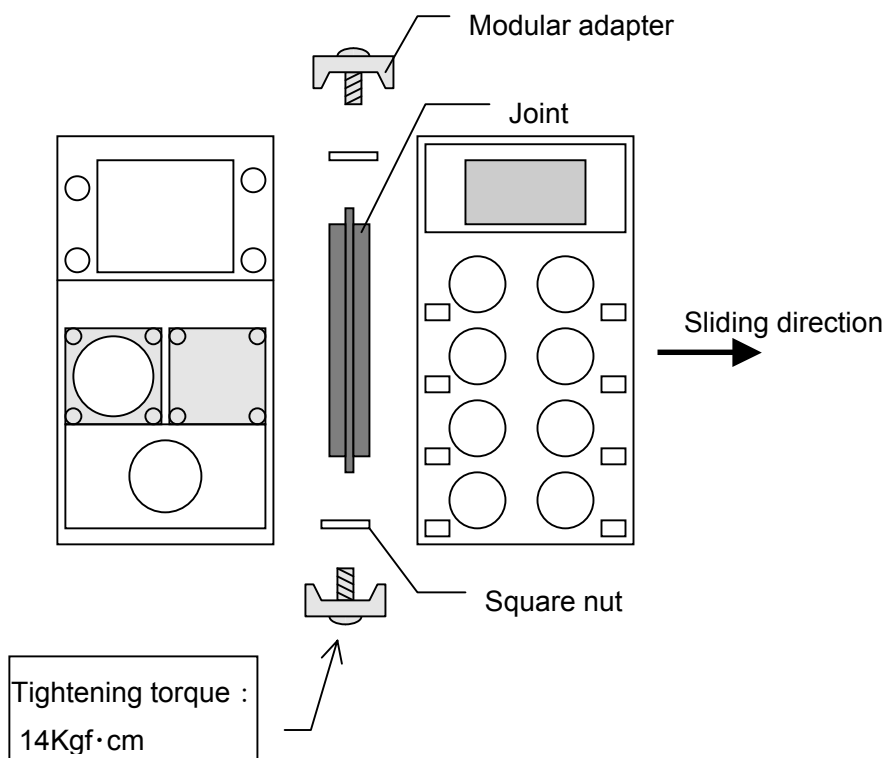

- To add DI units, remove end plate following the procedure above. Put it back when additional DI units are attached.

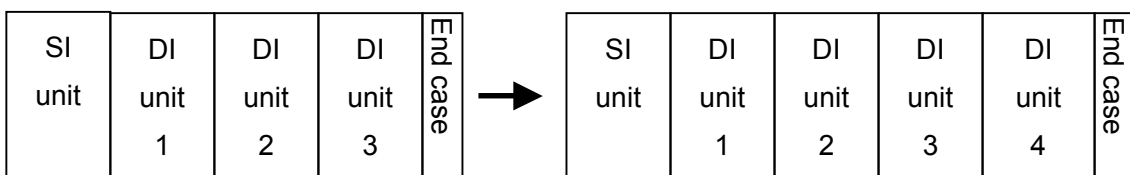

14 Troubleshooting

NET LED	Cause and Countermeasure
Light off	<p><u>PWR LED is also lighted off</u> <Countermeasure> Confirm if power for SI unit line is supplied. Confirm if cable for line is correctly wired. Replace SI unit if condition is not improved with above countermeasures.</p> <p><u>PWR LED is lighted on</u> <Countermeasure> Confirm if communication speed is set correctly. Replace SI unit if it is lighted off even though the communication speed is set correctly.</p>
Green flashing	<p><u>Connection standby</u> Indicates standby condition of communication between SI unit and Mater. <Countermeasure> Confirm if master is operating correctly. If scan list is used, confirm the slave is registered on the scan list correctly.</p>
Green light on	<p><u>Communication is shutdown</u> <Countermeasure> Confirm if CPU unit of PLC is operating.</p>

MOD/NET LED	Cause and countermeasure
Red flashing	<p>Communication line cut off error <Countermeasure> Confirm if communication line is not cut off. <Note> Red light also blinks when power of master is OFF during communication.</p>
Red light on	<p><u>Node address error</u> <Countermeasure> Confirm if there is a node with duplicated node address.</p> <p><u>BUS OFF error</u> Communication error is found. <u>Communication failure by noise is possible</u> Confirm if there is such as equipment or high pressure line which cause noise around communication line. Measure to separate communication line from source of the noise.</p> <p><u>Problem on wiring of communication line is possible</u> Confirm if terminating resistance (121 Ω) is connected on the both side of main communication line.</p> <p>Replace SI unit if red light of MOD/NET LED is on even though above countermeasures are performed.</p>



Note

SI unit will not recover automatically if red light of MOD/NET LED is on. Please supply power of SI unit line (communication and internal power) again.