



# Operation Manual

Reduced wiring system  
(Gateway unit (EtherNet/IP))

PRODUCT NAME

EX500-GEN1-X28

MODEL/ Series

**SMC Corporation**

# Table of Contents

	<u>Page No.</u>
Safety	2
Parts description	7
Installation	8
Wiring method	8
LED Display	9
Setting	10
Specifications	11
Specifications	11
I/O Mapping	13
Dimensions	14

## Safety

This manual contains essential information to prevent possible injury and damage to (users and other people, and property) and to ensure correct handling.

Please confirm understanding the definition of the following messages (signs) before going on to read the text, and always follow the instructions.

Also read carefully the instruction manual of relevant equipment or apparatus before use.

### ◆ Indications

IMPORTANT MESSAGES	
Read this manual and follow its instructions. Signal words such as WARNING CAUTION and NOTE will be followed by important safety information that must be carefully reviewed.	
<b>▲WARNING</b>	Indicates a potentially hazardous situation, which could result in a serious injury or death if you do not follow the instructions.
<b>▲CAUTION</b>	Indicates a potentially hazardous situation, which if not avoided, may result in minor injury or moderate injury.
<b>NOTE</b>	Gives you helpful information.

### ◆ Operator

- ◆ This operation manual has been written for those who have knowledge of machinery and apparatus that use pneumatic equipment and have full knowledge of assembly, operation and maintenance of such equipment.
- ◆ Please read this operation manual carefully and understand it before assembling, operating or providing maintenance to the SI Unit.

### ◆ Usage Restrictions

- ◆ This product is designed for use in general equipment for factory automation. Never use this product with equipment or apparatus that directly concerns human lives\*<sup>1</sup>, or if malfunction or fail can cause a critical loss.
  - \*1: Equipment or apparatus that directly concerns human lives means the following:
    - Medical equipment such as life support systems or equipment used in operating rooms.
    - Compulsory equipment required by law such as the Fire Prevention Law, Construction Law and etc.
    - Equipment or apparatus that conforms with the laws mentioned above.
- ◆ Contact our sales department when plans are made for the product to be used in the systems\*<sup>2</sup> such as equipment for the safety of persons or the equipment that seriously affects the public safety if fails. These usage need special consideration\*<sup>3</sup>.
  - \*2: The systems involve with the safety of persons or the systems that seriously affect the public if fail include the followings:
    - Nuclear reactor control systems in nuclear power plants, safety protection systems or other systems important for safety in nuclear power facilities.
    - Driving control systems of mass transportation and the flight control systems.
    - Equipment or apparatus that comes in contact with foods or beverages.
  - \*3: Special consideration means discussing the usage with our engineers to establish a safe system designed as fool-proof, fail-safe, redundant and etc.
- ◆ Special consideration of safety or maintainability should be taken to prevent hazard or loss caused by a failure or malfunction that is likely to occur in certain environmental conditions. The special consideration means to fully review the equipment or apparatus in design stage and to establish a backup system in advance such as a redundant system or fail-safe system.

## **WARNING**

- ◆ The compatibility of pneumatic equipment is the responsibility of the person who designs the Pneumatic system or decides its specifications.  
Since the products specified here are used in various operating conditions, their compatibility with the specific pneumatic system must be based on specifications or after analysis and / or tests to meet your specific requirements.
- ◆ Only trained personnel should operate pneumatically operated machinery and equipment.  
Compressed air can be dangerous if an operator is unfamiliar with it. Trained and experienced operators should perform assembly, handling or repair of pneumatic systems.
- ◆ Do not service machinery / equipment or attempt to remove components until safety is Confirmed.
  1. Inspection and maintenance of machinery /equipment should only be performed after confirmation of safe locked-out control positions.
  2. When equipment is to be removed, confirm the safety process as mentioned above. Cut the supply pressure from the equipment and exhaust all residual compressed air in the system.
  3. Before machinery / equipment is re-started, take measures to prevent quick extensions of the cylinder piston rod etc. (Bleed air into the system gradually to create back-pressure.)
- ◆ Contact SMC if the product is to be used in any of the following conditions:
  1. Conditions and environments beyond the given specifications, or if product is used outdoors.
  2. Installation on equipment in conjunction with atomic energy, railway, air navigation, vehicles, medical equipment, food and beverage, recreation equipment, emergency stop circuits, press applications, or safety equipment.
  3. An application which has the possibility of having negative effects on people, property, or animals.

## **⚠ WARNING**

- ◆ Do not disassemble, modify (including change of printed circuit board) or repair.  
An injury or failure can occur.
- ◆ Do not operate the product beyond specification range.  
Operation at a range that exceeds the specifications can cause a fire, malfunction, or damage to the unit.  
Verify the specifications before use.
- ◆ Do not use the product in an atmosphere containing combustible, explosive or corrosive gas.  
It can cause a fire, explosion or corrosion.  
The unit is not designed to be explosion-proof.
- ◆ The following instructions must be kept when using the product in an interlocking circuit:
  - Provide double interlocking by another system such as mechanical protection.
  - Check the product regularly to ensure proper operation.Otherwise malfunction can cause an accident.
- ◆ The following instructions must be kept while in maintenance:
  - Turn off the power supply
  - Stop the supplied air, exhaust the residual pressure and verify the release to atmosphere before performing maintenanceOtherwise an injury can occur.

## **⚠ CAUTION**

- ◆ Perform proper functional checks after maintenance.  
Stop operation when an abnormality is observed such, as the unit does not work properly.  
Safety can not be assured due to unexpected malfunction.
- ◆ Provide grounding for securing safety and noise resistance of reduced-wiring system.  
Individual grounding should be provided to the unit with short wire.

## NOTE

- ◆ Follow the instructions given below when handling reduced-wiring system :  
Or it will have a risk of being damaged and operating failure.
- ◆ The instructions on selection (installation, wiring, environment of use, adjustment, operation and maintenance) described below must also be followed.

### \*Product specifications

- Use the following UL recognized direct-current power supply.

(1) Limited voltage current circuit in accordance with UL508

A circuit whose power is supplied by secondary coil of a insulating transformer that meets the following conditions

- Maximum voltage (with no load) : less than 30Vrms (42.4V peak)
- Maximum current : (1) less than 8A(including when short circuited)

(2) limited by circuit protector (such as fuse) with the following ratings

No load voltage (V peak)	Max. current rating (A)
0 to 20 [V]	5.0
Above 20 to 30 [V]	100 / peak voltage

(2) A circuit using max. 30V rms or less (Class-2 circuit), whose power is supplied by Class-2 power supply unit in accordance with UL1310 or Class-2 power supply unit in accordance with UL1585

- Operate reduced-wiring system with the specified voltage.  
Operation with a voltage beyond specifications could cause malfunction or damage the unit.
- Reserve a space for maintenance  
Be sure to keep a space for maintenance when designing layout of the unit.
- Do not remove nameplate.  
Otherwise maintenance error and misreading of an operation manual could cause damage or malfunction.  
It may also result in nonconformity to safety standards.
- Use caution with inrush current when supplying the power.  
With some loads the device may malfunction because built-in over current protection circuit is accidentally activated due to initial charge current.

### ◆ Precautions on handling

#### \*Installation

- Do not drop, hit or apply excessive shock to the unit.  
The unit could be damaged due a drop, hit or excessive shock.
- Follow the specified tightening torque.  
Excessive tightening torque can break screws.  
The screw should be tighten with the specified torque, otherwise IP65 protection can not be guaranteed.

#### \*Wiring (including plugging in/out of connector)

- Do not bend the cables or apply excessive force to them by pulling or placing heavy load.  
Wiring subject to bending or tensile stress could cause the cables to break.
- Connect wires and cables correctly.  
Incorrect wiring could break the reduced-wiring system.
- Do not connect wires while the power is supplied.  
Otherwise it can break the reduced-wiring system or I/O devices could be damaged or malfunction.
- Do not connect power cable or high-voltage cable in the same wiring route as the unit's wiring.  
Otherwise the wires to the reduced-wiring system can be interrupted with noise or induced surge voltage from power lines or high-voltage lines and unit could malfunction.  
Keep wiring of the unit and each I/O device separate from that of power line and high voltage line.
- Verify the insulation of wiring.  
Insulation failure (interference with other circuit, poor insulation between terminals and etc.) could introduce excessive voltage or current to the reduced-wiring system or each I/O device and damage them.

- Keep power line for solenoid valves separate from power line for input and control unit. Otherwise wires can be interrupted with noise or induced surge voltage causing malfunction.
- Take proper measurements such as noise filter against noise when the reduced-wiring system is incorporated in equipment or devices. Otherwise contamination with noise can cause malfunction.

#### **\*Environment**

- Consider operating environment suitable for protection class.
  - Splash proof, Protection Class IP65, can be achieved for SI unit when valve, output block and end plate are installed properly and also the wiring ports are treated properly.
  - Splash-proof, Protection Class IP65, can be achieved for Input Manifold when Input unit, Input block and end block are installed properly and also the wiring ports are treated properly.
- Take sufficient shielding measures when the unit is installed.
  - Insufficient measures could cause malfunction or failure.
  - Verify the effect of the measures after incorporating the unit in equipment or devices:
    - (1) A place where noise due to static electricity is generated
    - (2) A place where electric field strength is high
    - (3) A place where there is radioactive radiation
    - (4) A place near power line
- Do not use the unit near by a place where electric surge is generated.
  - Internal circuit elements of the reduced-wiring system can deteriorate or break when equipment generating a large surge (electromagnetic lifter, high frequency induction furnace, motor, etc.) is located near the reduced-wiring system. Provide surge preventives, and avoid interference with line for the equipment.
- Use the reduced-wiring system equipped with surge absorber when a surge-generating load such as solenoid valve is driven directly.
  - Direct driving of a load generating surge voltage can damage reduced wiring system.
- Prevent foreign objects such as remnant of wires from entering the unit.
  - Take proper measures for the remnant not to enter the reduced-wiring system in order to prevent failure or malfunction.
- Do not expose the reduced-wiring system to vibration and impact.
  - Otherwise failure or malfunction could occur.
- Keep the unit in specified ambient temperature range.
  - Otherwise malfunction could occur.
  - Do not use reduced-wiring system in a place where temperature suddenly changes even within the specified range.
- Do not expose the reduced-wiring system to heat radiation from a heat source located nearby.
  - Malfunction could occur.

#### **\*Adjustment and Operation**

- Use precision screwdriver with a small flat blade for setting Rotary switch.

#### **\*Maintenance**

- Perform maintenance and check regularly.
  - Otherwise an unexpected malfunction of the components of the unit could occur due to a malfunction of the whole unit.
- Perform a proper functional check.
  - Stop operation when an abnormality is observed such, as the device doesn't work properly.
  - Otherwise an unexpected malfunction of the unit component can occur.
- Do not use solvents such as benzene, thinner or other to clean the reduced-wiring system.
  - They could damage the surface of the body and erase the indication on the body.
  - Use a soft cloth to remove stains. For heavy stains, use a cloth soaked with diluted neutral detergent and fully squeezed, then wipe up the stains again with a dry cloth.

# Parts description

## • Parts description

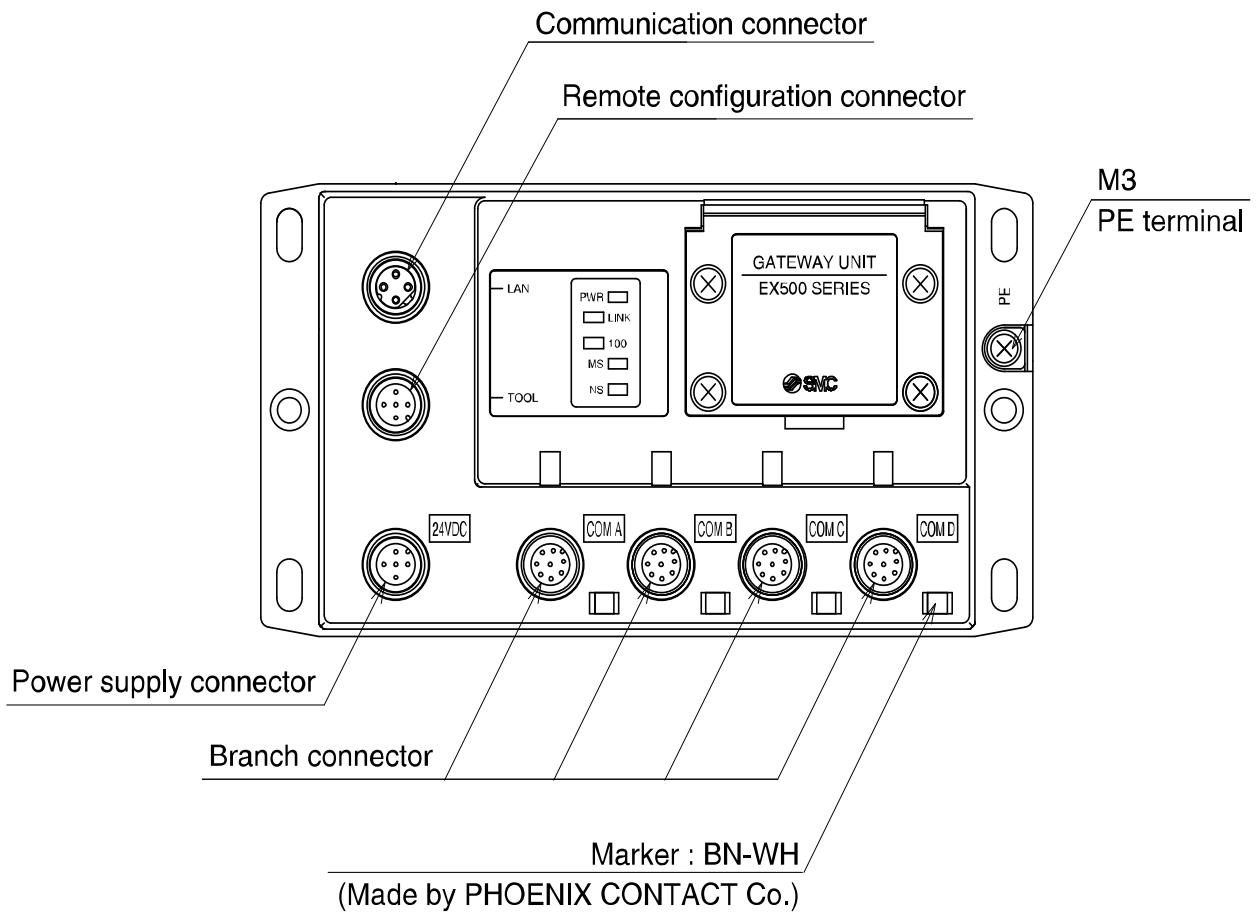

# Installation

## ■ Wiring method

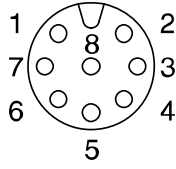
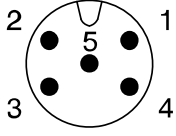
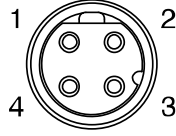
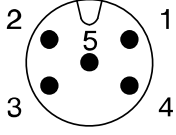
Connector	Item	Specification
Branch connector	Type	M12 connector (8 pin, socket)
	Pin assign	1. RD+ 2. RD- 3. TD+ 4. TD- 5. 24V DC (for solenoid valve) 6. 0V (for solenoid valve) 7. 24V DC (for power source) 8. 0V (for power source) 
Power supply connector	Type	M12 connector (5 pin, plug)
	Pin assign	1. 0V (for solenoid valve) 2. 24V DC (for solenoid valve) 3. 0V (for input and control) 4. 24V DC (for input and control) 5. FG 
Field-bus (Ethernet) connector	Type	M12 connector (4pin, socket D-coding)
	Pin assign	1. Tx+ 2. Rx+ 3. Tx- 4. Rx- 
Remote configuration connector	Type	M12 connector (5 pin, plug)
	Pin assign	1. N.C. 2. RxD 3. N.C. 4. TxD 5. GND 

## LED Display

### • LED

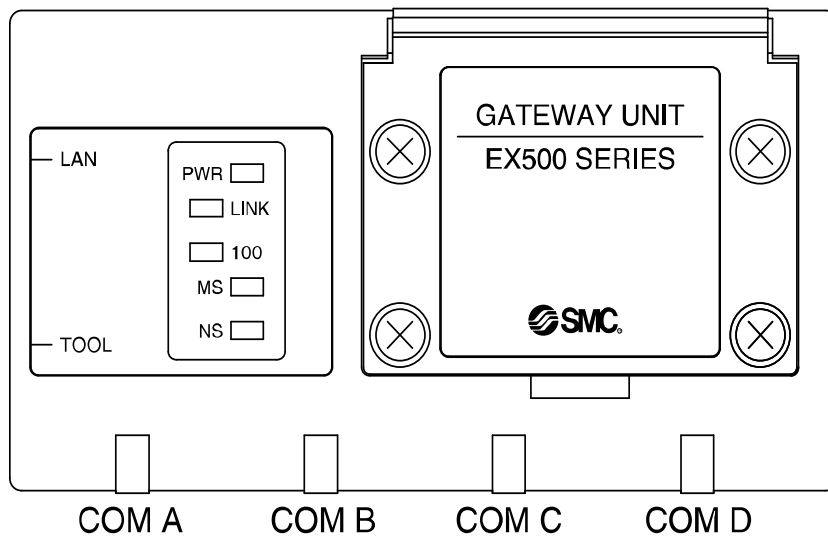

LED	State	Indicate
PWR	Detect a drop of solenoid power voltage (less than 20V)	OFF
	Power supply is of normal voltage for solenoid valves	Solid green
LINK	Power-off / Unit initializing	OFF
	Connected to an Ethernet network	Solid green
	Rx / Tx activity	Flash green
100	10Mbps transmitting	OFF
	100Mbps transmitting	Solid green
MS	Power off	OFF
	Normal operation	Solid green
	Missing or incorrect configuration	Flash green
	Recoverable internal fault	Flash red
	Unrecoverable internal fault	Solid red
NS (*1)	No power or no IP address	OFF
	Device has no established EIP connection	Flash green
	Device has at least one established EIP connection	Solid green
	One or more established EIP connections has timed out	Flash red
	Duplicated IP address detected	Solid red
COM A	No data	OFF
	Port is active and receiving data.	Solid green
COM B	No data	OFF
	Port is active and receiving data.	Solid green
COM C	No data	OFF
	Port is active and receiving data.	Solid green
COM D	No data	OFF
	Port is active and receiving data.	Solid green

\*1) EIP connection means Fieldbus protocol (EtherNet/IP) level connection.

# Setting

## • Switch setting

Turn off the power when setting switch or to open the switch protection cover.

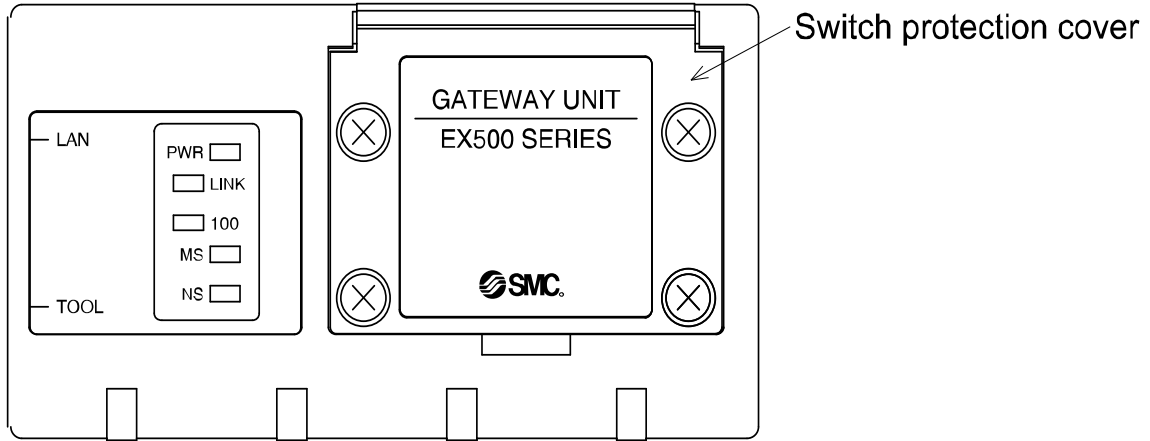

Open the switch protection cover and set the switch with a flat blade screw driver.

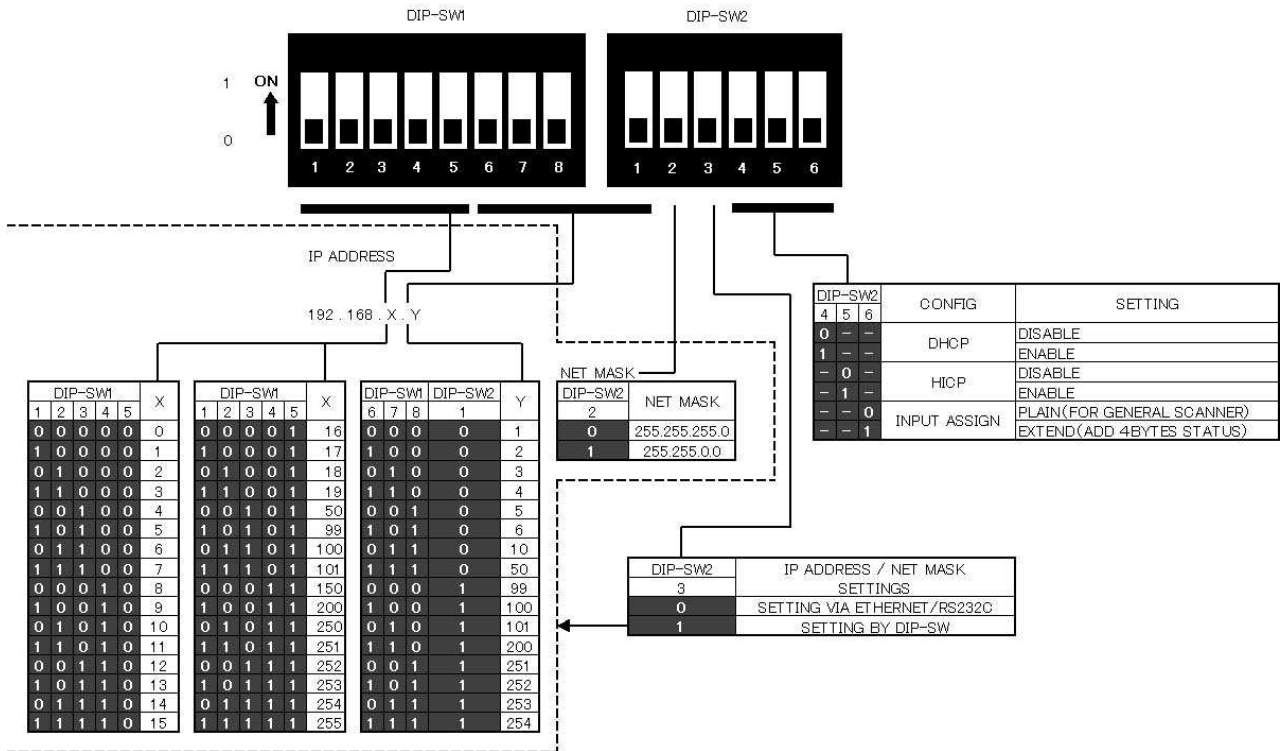

## Specification

### ■ Specifications

Specification are subject to change without prior notice and without any obligation on the part of the manufacturer.

### ● General Specification

Item	Specification
Rated voltage	24VDC
Power supply voltage	Input and control power supply : 24VDC +10%/-10%
	Solenoid valve power supply : 24VDC +10%/-5% (Warning of voltage drop when lower than approx. 20V)
Current consumption	200mA or less (only GW Unit)
Input / Output points	Maximum 64 inputs / Maximum 64 outputs
Input / Output branches	4 branches (one branch 16 inputs / 16 outputs)
Weight	470g

### ● General Specification (continue)

Item	Specification
Enclosure	IP65
Withstand voltage	1500VAC 1nim. (between PE-external terminal package)
Insulation resistance	2M $\Omega$ or more (500VDC meg. between PE-external terminal package)
Momentary power failure	1m sec. or less
Ambient temperature	+5°C to +45°C
Ambient humidity	35% to 85%RH (without condensation)
Preservation temperature	-25°C to +70°C
Vibration proof	10Hz to 57Hz 0.35mm (constant amplitude)
	57Hz to 150Hz 49m/s <sup>2</sup> (constant speed)
	2 hours per each direction of $\pm$ X, Y and Z
Shock resistance	Peak value : 147m/s <sup>2</sup>
	3 times per each direction of $\pm$ X, Y and Z
Applicable altitude	Less than 1000m above sea

• **Communication specification**

• Field-bus (Ethernet)

Item	Specification
Protocol	Ethernet (IEEE802.3)
Media system	100BASE-TX
Cable	TIA / EIA-568-B 2pair CAT.5 Twist-pair (Recommend to conform to EtherNet/IP)
Data rate	10Mbps / 100Mbps (Auto negotiation)
Duplex	Full-duplex / Half-duplex (Auto negotiation)
Internet protocol	IPv4 (RFC791)
Supported protocols	UDP (RFC768)
	TCP (RFC793)
	ARP (RFC826)
	ICMP (RFC792)
	IGMP (RFC1112/2236)
Fieldbus protocol	EtherNet/IP (CIP) Release1.0
I/O Input size	16byte (last 8bytes are reserved area for extension)
I/O Output size	16byte (last 8bytes are reserved area for extension)
Port No.	44818 (0xAF12)
IP Address setting method	
ARP/Ping	Support
DHCP	Support
Device information (*1)	
Vendor ID	0x0007 (SMC)
Device Type	0x000c (Communication Adapter)
Product Code	0x0068

• Remote configuration port

Item	Specification
Communication standard	RS232C
Communication mode	Asynchronous / ASCII code set
Data rate	19200bps
Data length	8bit
Parity	Even
Stop bit	1bit

• Input / Output branch

Item	Specification
Protocol	SMC original protocol
Communication Speed	750k bit / sec.
Length of cable	Less than 5m (Total. 10m Max.)

• I/O Mapping

Offset (word)	Branch	Data (2 byte)															
		MSB								LSB							
		15								7							
		15	14	13	12	11	10	9	8	7	6	5	4	3	2	1	0
0	COM A	15	14	13	12	11	10	9	8	7	6	5	4	3	2	1	0
1	COM B	31	30	29	28	27	26	25	24	23	22	21	20	19	18	17	16
2	COM C	47	46	45	44	43	42	41	40	39	38	37	36	35	34	33	32
3	COM D	63	62	61	60	59	58	57	56	55	54	53	52	51	50	49	48
4-7	-	Reserved								Reserved							

# Dimensions

## ■ Dimensions

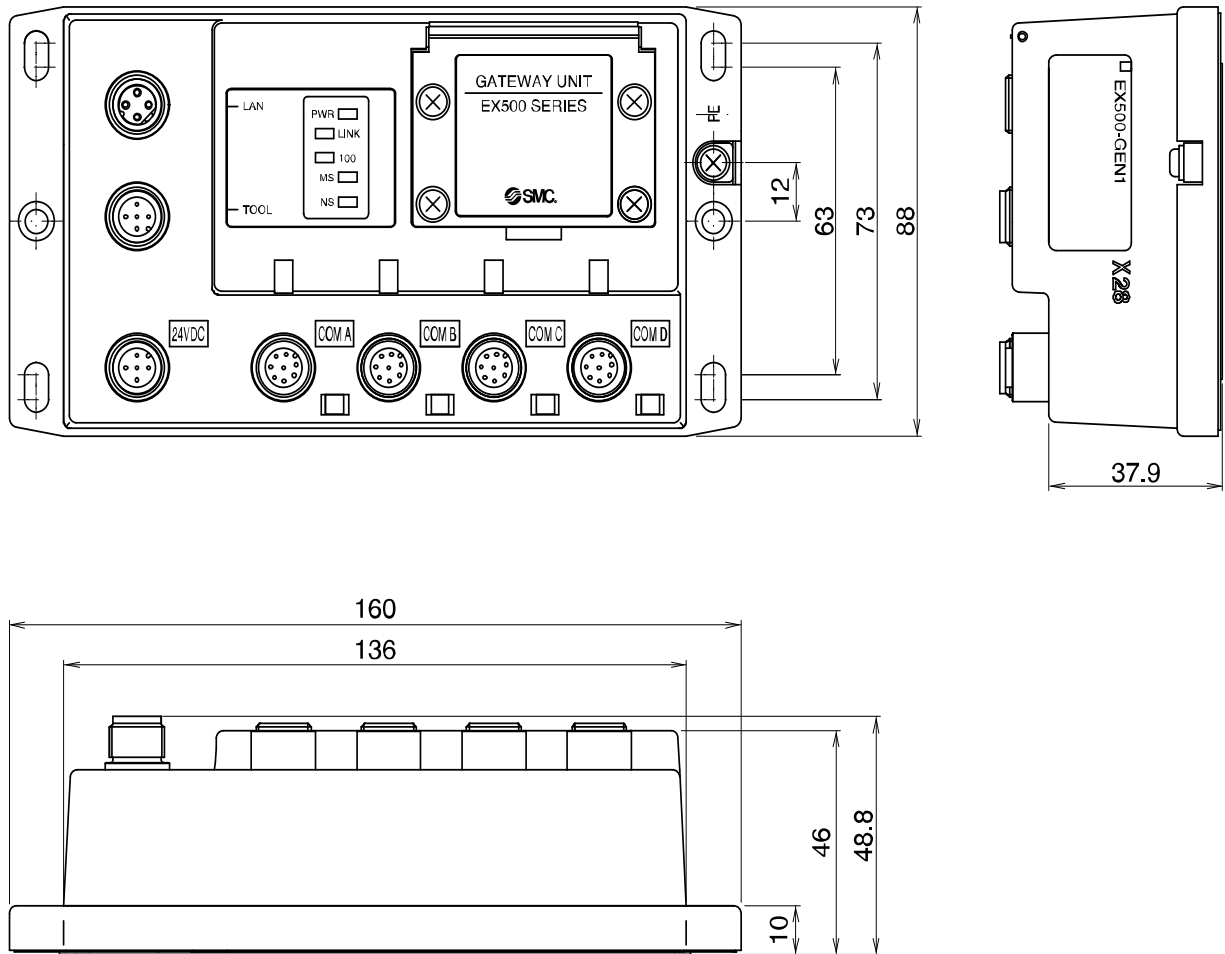

Revision history

# SMC Corporation

URL <http://www.smcworld.com>

## Phone

AUSTRIA / (43) 2262-62 280	ITALY / (39) 02-92711
BELGIUM / (32) 3-355 1464	NETHERLANDS / (31) 20-531 8888
CZECH REP. / (420) 5-414 24611	NORWAY / (47) 67 12 90 20
DENMARK / (45) 70 25 29 00	POLAND / (48) 22-548 50 85
FINLAND / (358) 9-859 580	PORTUGAL / (351) 2 610 89 22
FRANCE / (33) 1-64 76 1000	SPAIN / (34) 945-18 4100
GERMANY / (49) 6103 4020	SWEDEN / (46) 8-603 0700
GREECE / (30) 1- 342 6076	SWITZERLAND / (41) 52-396 3131
HUNGARY / (36) 1-371 1343	TURKEY / (90) 212 221 1512
IRELAND / (353) 1-403 9000	UNITED KINGDOM / (44) 1908-56 3888

Note: Please acknowledge that this content might change without a prior notice.

Each company might be using the name of the commodity of this manual publishing respectively as a trademark.

© 2004 SMC Corporation All Rights Reserved

